

*Lakeside Plantation
Community Development District*

Agenda

June 24, 2013

AGENDA

Lakeside Plantation

Community Development District

13574 Village Park Drive, Suite 265, Orlando, FL 32837
Phone: 407-841-5524 – Fax: 407-839-1526

June 18, 2013

Board of Supervisors
Lakeside Plantation
Community Development District

Dear Board Members:

The special meeting of the Board of Supervisors of the Lakeside Plantation Community Development District will be held **Monday, June 24, 2013 at 7:00 p.m. at the Lakeside Plantation Clubhouse, 2200 Plantation Blvd, North Port, FL.** Following is the advance agenda for the meeting:

1. Roll Call
2. Pledge of Allegiance
3. Audience Comments
4. Supervisor Replies
5. Business Items
 - A. Discussion of Refinancing the Series 1999 Bonds
 - B. Consideration of Pool Lift Proposals
 - C. Consideration of Proposal from Bloomings Landscape & Turf Management Addressing Line of Sight Issues at Intersections
 - D. Consideration of Proposal for Gym Flooring
 - E. Consideration of Proposal from Fitness Logic to Provide Quarterly General Maintenance and Cleaning of Gym Equipment
 - F. Discussion of Condition of Pool Deck
6. Other Business
7. Supervisor's Requests
8. Adjournment

The fifth order of business is Business Items. Section A is the discussion of refinancing the Series 1999 Bonds. Attached is a memorandum prepared by MBS Capital Markets regarding the current status of the refinancing effort and recommendations for moving forward. Section B is the consideration of pool lift proposals. Enclosed for your review is the proposal from Leisure Aquatic Products, Inc. An additional proposal will be provided under separate cover. Section C is the consideration of proposal from Bloomings Landscape & Turf Management addressing the line of sight issues at various intersections. Bloomings has been directed to move forward with removal of the plant material causing line of sight issues and will be in attendance at the meeting to provide the Board with options and recommendations to replace the plant material. Section D is the consideration of a proposal for gym flooring. This item will be presented by Joe Montagna, Amenities Manager, and backup will be provided under separate cover. Section E is the consideration of proposal from Fitness Logic to provide quarterly general maintenance and cleaning of gym equipment. A copy of the proposal is

enclosed for your review. Section F is the discussion of the condition of the pool deck. Joe Montagna, Amenities Manager, will discuss this issue with the Board.

The balance of the agenda will be discussed at the meeting. In the meantime, if you have any questions, please contact me.

Sincerely,

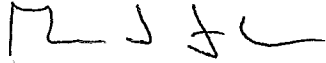
A handwritten signature in black ink, appearing to read 'G S Flint', written in a cursive style.

George S. Flint
District Manager

Cc: Michael Eckert, District Counsel
Dorian Popescu, District Engineer
Joe Montagna, Amenities Manager
Darrin Mossing, GMS

Enclosures





MBS CAPITAL MARKETS, LLC

MEMORANDUM

To: Board of Supervisors, Lakeside Plantation CDD

From: Ed Bulleit, MBS Capital Markets, LLC

Re: Refinancing Update

Date: June 18, 2013

As discussed at the board meeting last week, we had not yet received the District's tax roll which would have afforded us the opportunity to perform sufficient due diligence activities to determine, without limitation, the allocation of assessments to the various product types and land uses in the District. Such analysis is integral to properly analyzing the credit dynamics to determine if it is possible for the District to receive an investment grade rating. Based upon the efforts of your new district manager, we received the tax roll on Friday and determined that approximately 17% of the assessments are levied on five commercial properties of which only one has vertical construction thereon. This high concentration among a small number of non-residential taxpayers will be a hindrance to obtaining an investment grade rating unless the structure of the refunding bonds is modified to essentially mitigate this risk. Fortunately, we have successfully developed and employed a modified structure to accommodate this credit issue for other recent CDD refinancing transactions. However, a portion (17%) of the refunding bonds will be issued without a rating thereby increasing the average interest cost of the refunding bonds.

We have run a new financial analysis to determine the economic impact of the modified structure which reduced the annual debt service reduction to approximately 4% while the principal amount of the assessment would increase by approximately 16%. These results were reported to the other District staff members on a conference call this afternoon and a determination was made that it would not be prudent to proceed with commencing the assessment process until further credit work and financial analysis was completed. Such effort would include the preparation and submittal of a credit package to the rating agency (S&P) which would be done solely at our cost. We would then bring the results of the rating effort to the Board along with an updated financial analysis upon receipt of S&P's decision. Again, we felt that this was the most prudent approach and would serve to prevent the District from incurring potentially unnecessary costs towards the refinancing effort.

We appreciate the opportunity to serve as the District's investment banker and will report back to the Board as soon as we hear back from S&P following submittal of a credit package.

4890 WEST KENNEDY BLVD. SUITE 288
TAMPA, FLORIDA 33609
PHONE: 813.281.2700

152 LINCOLN AVENUE
WINTER PARK, FLORIDA 32789
PHONE: 407.622.0130

8583 STRAWBERRY LANE
LONGMONT, COLORADO 80503
PHONE: 303.652.0205

1005 BRADFORD WAY
KINGSTON, TENNESSEE 37763
PHONE: 865.717.0303



7249 Country Club Rd.
Byron, MN 55920

(507) 288-6289
1-800-288-8808
FAX (507) 288-4170
www.leisureaquatic.com

June 18, 2013

Dear Joe,

Thank you for your interest regarding how we here at Leisure Aquatic Products, Inc. can ensure that you achieve timely compliance with the amended 2010 ADA standards. As one of the preeminent lift distributors who also employ their own installation crews, we ensure that your lifts are installed to current industry standards and operate safely. Our installation crews travel from the East Coast to the West Coast, so location of properties will not present any logistical problems. At this point in time, we have currently sold and installed well over 3,000 lifts, so we are well-versed in handling all situations that may arise.

Another pragmatic consideration is how delaying the purchase of an ADA-approved lift will affect your ability to timely achieve compliance with the 2010 ADA Standards. Currently, only approximately 30% of public accommodations falling within the purview of the 2010 ADA Standards have undertaken action to become compliant. Delaying action may potentially leave businesses susceptible to being in violation of the 2010 ADA Standards as the deadline approaches and lead times are greatly extended due to the high influx of orders. Ordering now will also ensure that you are familiar with the operational mechanics of the lift. The aforementioned are all reasons to consider purchasing a lift now, as waiting may leave one exposed to legal recourse in the future.

Leisure Aquatic Products, Inc. is a direct distributor of lift chairs that meet the 2010 ADA Standards; and because we are the exclusive distributor for SR Smith, Spectrum, Aqua Creek and Global Lift Corp., we can give you the best price. Leisure Aquatic has 33 years of experience in the pool and spa business, and we back our sales with service and installation. We are a family business that prides itself on customer service and dependability.

To summarize, the aforementioned demonstrates our ability to assist you, including:

- we not only distribute ADA-approved lifts but also conduct the installations to current industry standards;
- location of properties presents no logistical concerns, as our installation teams travel Nationwide and are well-adept at working within such constraints; and
- we here at Leisure Aquatic Products, Inc. provide unparalleled customer service, ensuring that quality and satisfaction are always at the forefront!

If you have any questions regarding lift models, prices, or general questions, please feel free to contact us by phone or email.

Sincerely,

Craig Milde, President
Leisure Aquatic Products, Inc.
507-288-6289

spas • pools • saunas • service • pool lifts

Q U O T A T I O N

LEISURE AQUATIC PRODUCTS, INC.
 7249 Country Club Road
 Byron, MN 55920
 Phone #: (507)288-6289

PHONE #:
 ALT. #:
 P.O. #:
 TERMS: Cash
 SALES ORDER #: 1020432
 SALES TYPE #: Quote

DATE: 6/18/2013
 INVOICE #:
 CUSTOMER#: 106763
 CP: LC1
 LOCATION: 1
 STATUS: Pending

BILL TO 106763

LAKE SIDE PLANTATION
 2200 Plantation Blvd
 NORTH PORT, FL

SHIP TO

LAKE SIDE PLANTATION
 2200 Plantation Blvd
 NORTH PORT, FL

MFR	PRODUCT NUMBER	DESCRIPTION	QTY SOLD	QTY BO	PRICE	NET	TOTAL
GLO	R-375	ROTATIONAL SERIES	2	0	\$5,499.00	\$2,899.00	\$5,798.00
GLO	COVER STANDARD	COVER STANDARD	2	0	\$150.00	\$75.00	\$150.00
****	SHIP	SHIPPING / HANDLING	2	0	\$175.00	\$175.00	\$350.00
****	LABOR	DELUXE INSTALLATION LABOR	2	0	\$1,300.00	\$1,300.00	\$2,600.00

NORMAL STANDARD INSTALLATION \$1,400.00. INCLUDES ANCHOR
 INSTALL, BOND, GROUT. NORMAL DELUXE INSTALLATION \$2,400.00
 INCLUDES STANDARD PLUS PUTTING THE LIFT TOGETHER
 AND DEMO.

FREE ROOM FOR INSTALLATION CREW, IF NECESSARY

1/2 DOWN DUE FOR INSTALLATION.

LIFTS REQUIRE FULL PAYMENT WHEN ORDERING.

EXTRA COSTS: PERMITS, IF NECESSARY.

Leisure Aquatic Products, Inc Authorized Signature

Date 6/18/13

Acceptance of Proposal

Date _____

SUBTOTAL: \$8,898.00
 TAX: \$0.00
 ORDER TOTAL: \$8,898.00

Rotational Series 375

R-375

Standard Features

- ADA Compliant Pool Lift
- Stainless Steel Construction
- Powder Coat Finish
- Lift Capacity - 375 lbs.
- Battery Powered 24 volt system
- User Friendly controls
- Lifetime Structural Warranty
- Arm Rests
- Foot Rest
- Safety Seat Belt
- UPS Packaging for easy shipping
- Can be used for spas and pools
- Clears obstacles up to 10" tall
- UV Resistant
- Includes Battery Charging Station
- Sleeve Anchor System (Optional)
- Rotates to the right 360 degrees or to the left 360 degrees
- Works with most existing anchors 1.9" x 6" deep
- Adapter optional to fit other anchors
- Key Lock Out System

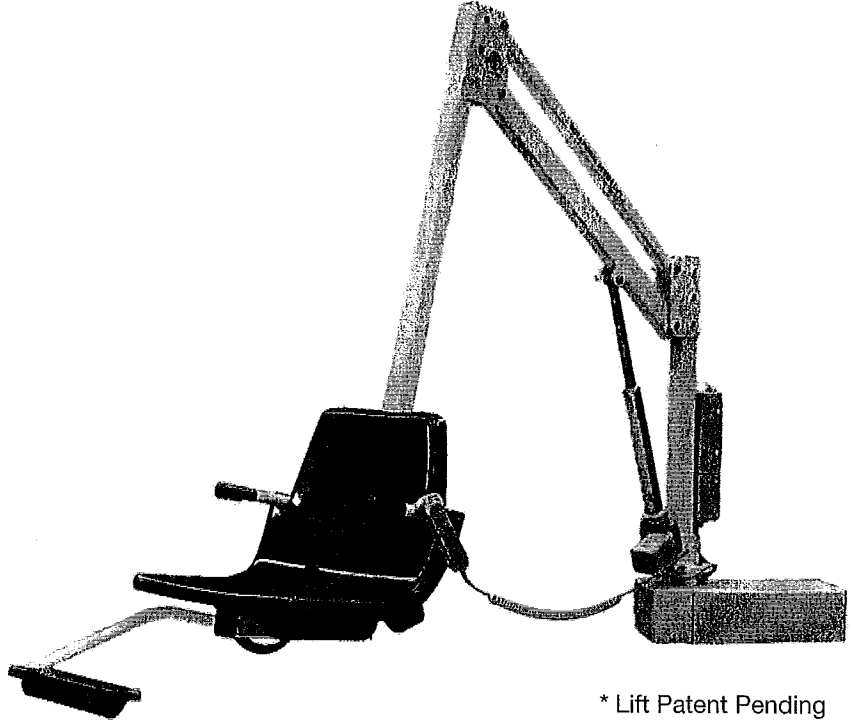

* Lift Patent Pending

www.GlobalLiftCorp.com

Rotational Series Options



Protective Cover



Extra Battery



Global Lift Corp. Products are Laboratory Tested to meet ADA Standards

2012

New ADA Laws

- All of our lifts are compliant with the New ADA Laws
- All swimming pools in the USA that fall under Title II or Title III need to comply with the new laws.

Title II (Public Industry) municipal pools, school pools, government owned pools, etc.

Title III (Private Industry) place of recreation, place of lodging, which addresses public accommodations

- Existing pools shall become compliant with accessibility by March 15, 2012
- There are tax incentives available
See details at www.GlobalLiftCorp.com

R-375

LIFT CONFIGURATOR

PLEASE CHOOSE WHICH APPLICATION YOUR POOL GUTTER BEST REPRESENTS

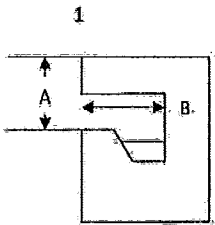

Fully Recessed Gutter

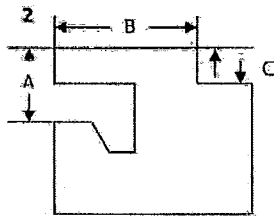

Fully Recessed Gutter
W/ parapet

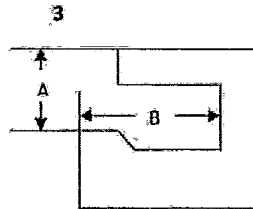

Partially Recessed
Gutter

LEGEND	
A	= Distance from pool deck to water line
B	= Width of Gutter
C	= Width of Curb
D	= Height of Curb

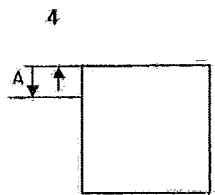

Gutter less Deck

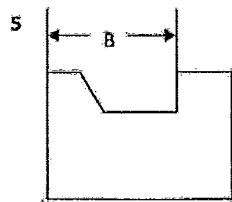

Flush Gutter & Deck
With or without bull
nose

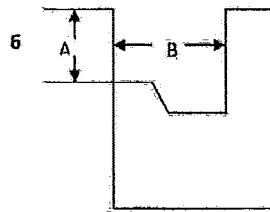

Rollout Gutter

LEGEND MEASUREMENTS MIN/MAX	
A	= 0" - 12"
B	= 0" - 28"
C	= 0" - 10"

NOTE: If your pool doesn't fall within these measurements, please contact your dealer for assistance.

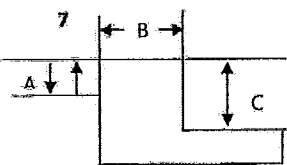

Above Ground Pool

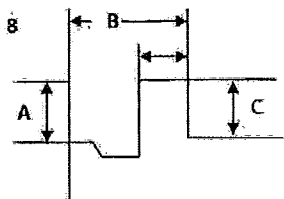

Gutter System with Curb

Dealer:

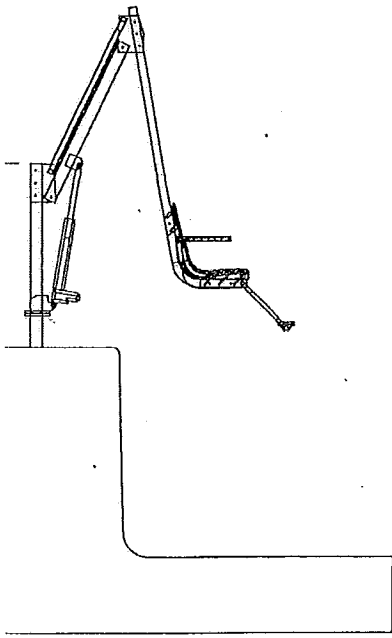

SIDE VIEW (UP)
NTS

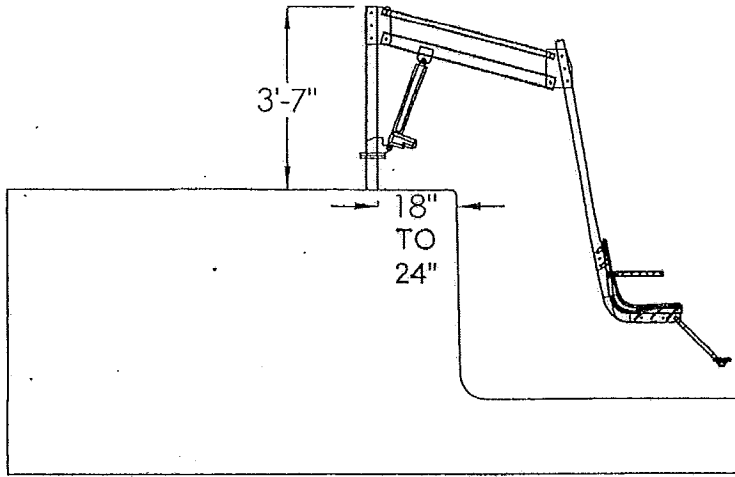

SIDE VIEW (DOWN)
NTS

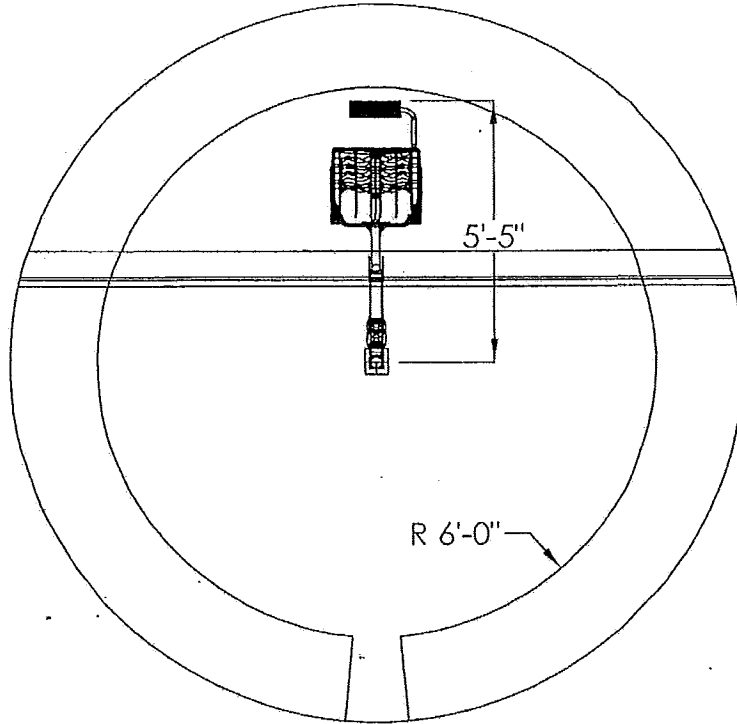
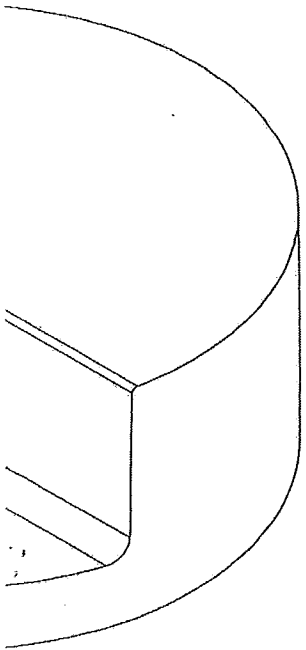

355° ROTATION
TOP VIEW
NTS

GB Collins Engineering P.A.
Certificate of Authorization 27934

Shunned, St. 2246-1010-98-55740
4208 Poppen Road
Blumenfeld, PA 15756
Phone: (717) 442-8442
Fax: (717) 442-6288
gt_collins@verizon.net

Standard ADA
Lift Installation

LEISURE AQUATIC PRODUCTS

ADL
3/20/12

GLOBAL LIFT CORP - MODEL R-375
1 (866) 712-0606

Fitness Logic

3011 Alt. 19

Palm Harbor, FL 34683

727-784-4964 - Fax 727-784-0223

e-mail fitlogic@aol.com

Quote

Date	Quote #
6/17/2013	18732

Name / Address
Lakeside Plantation 2200 Plantation Blvd, North Port, FL 3428



P.O. No.	Terms	Rep
	Net 10	RR

Item	Description	Qty	Rate	Total
Quote Mainten...	Quarterly General Maintenance and cleaning of all equipment per visit - Labor Only.	1	145.00	145.00

Thank you for the opportunity to quote. The above prices are valid for 30 days from quote.

Subtotal \$145.00

Sales Tax (7.0%) \$0.00

Total \$145.00

A Deposit of 20% is Required on the Sale of Equipment.

Signature: _____

Date: _____