

**LAKESIDE PLANTATION
COMMUNITY DEVELOPMENT DISTRICT
BOARD OF SUPERVISORS
REGULAR MEETING
SEPTEMBER 23, 2010**

**LAKESIDE PLANTATION
COMMUNITY DEVELOPMENT DISTRICT
AGENDA
SEPTEMBER 23, 2010 at 7:00 PM**

Lakeside Plantation Clubhouse
Located at 2200 Plantation Boulevard, North Port, Florida 34289

District Board of Supervisors	Chairman Vice Chairman Supervisor Supervisor Supervisor	Bill Capozzi Bob Babik Ronald Bock David Polk Gwynne Balson
District Manager	District Management Services, LLC	Brian Lamb
District Attorney	Shumaker, Loop & Kendrick, LLP	Jeffrey Russell
District Engineer	DMK	Dorian Popescu Sr.

All cellular phones and pagers must be turned off while in the meeting room

AGENDA: The agenda is available from the District's Local Office, and soon to be on the District's website. There shall be an official agenda for every meeting of the Board of Supervisors that will be created by the Chairman and District Manager and distributed seven (7) days in advance of the meeting, which shall determine the order of business conducted at the meeting. Any Supervisors or Staff that would like to add an item to the agenda must contact the District Manager at least 7 days prior to the meeting. The decision to list the item will be at the discretion of the Chair. Agenda will be split into allocated time frames for each section. If an agenda item can not be resolved or answered within the allocated time frame, the agenda item can be continued until the next meeting. Items not listed on the agenda raised at a meeting will not be considered until the next meeting unless deemed time sensitive.

CONSENT ITEMS: These are items which are not discussed individually and are voted on as a group. The consent items considers non-controversial, no policy implications, and is approved without discussion. A Board Member may remove an item from the consent items to be considered, which is followed by Board vote on the remainder of the consent items.

REGULAR AGENDA ITEMS: These are items which the Board will discuss individually in the order and time frame listed on the agenda.

WHO MAY SPEAK: The public is encouraged to offer comment to the Board at the meeting on an agenda item during the Audience Comments portion of the meeting. Please complete a public comment card and give it to the District Manager prior to the agenda item being discussed.

ADDRESSING THE BOARD: When your name is called, please stand and state, for the record, your name and address. All comments shall be directed to the Board, not to a particular member thereof or to the general public. Persons addressing the Board during general public comment shall limit their remarks to five (5) minutes. To conserve time, delegation speakers will be selected by the Chairman to address the board on behalf of groups containing more than 5 individuals who share a similar opinion and/or comment.

DECORUM: Any person making personal, impertinent or slanderous remarks or who becomes boisterous while addressing the Board or while attending the Board meeting will be asked to refrain and/or asked to leave from the room, if appropriate.

ADA COMPLIANCE: Pursuant to provisions of the Americans with Disabilities Act, any person requiring special accommodations to participate in these meetings is asked to advise the District's Local Office at least 48 hours before the meetings. If you are hearing or speech impaired, please contact the Florida Relay Service at 1 (800) 955-8770, who can aid you in contacting the District Office.

APPEALING A DECISION: If any person decides to appeal any decision made by the Board with respect to any matter considered at these meetings, such person will need a record of the proceedings and such person may need to ensure that a verbatim record of the proceedings is made, at his or her own expense, and which record includes the testimony and evidence on which the appeal is based.

September 15, 2010

Board of Supervisors
Lakeside Plantation Community Development District

Dear Board Members:

The Regular Meeting of the Board of Supervisors of the Lakeside Plantation Development District will be held on **Thursday, September 23, 2010 at 7:00 p.m.**, EST at the Lakeside Plantation Clubhouse, located at 2200 Plantation Boulevard, North Port, Florida 34289. Included below is the agenda:

- 7:00 PM Call to Order**
A. Overview of Meeting Guidelines
B. Roll Call
C. Pledge of Allegiance
- 7:05 PM Audience Comments on Agenda items**
- 7:25 PM Business Administration**
A. Review of Minutes of Board of Supervisors Meeting on August 12, 2010 Tab 1
B. Review of Revised Resolution #2010-14 - FY 2010/2011 Annual Meeting Schedule..... Tab 2
- 7:35 PM Business Items**
A. Discussion of Reserve Study & Overview of Funds (under separate cover)
B. Discussion of SLK Invoices Tab 3
C. Discussion of Audio System Proposal Tab 4
D. Overview of Clubhouse Renovations and future needs Tab 5
E. Consideration of Pool Resurfacing Tab 6
F. Discussion of Standard Pacific Road Request (Towns) Tab 7
G. Entrance Sign Update (Under separate cover)
H. Consideration of Fountain Repairs and Improvements..... Tab 8
I. Acceptance of Deed for Fire District Parcel Tab 9
- 8:45 PM Staff Reports**
A. District Counsel
B. District Engineer
C. District Manager Reports
1. Financial Statements Period Ending July 31, 2010 Tab 10
2. Financial Statements Period Ending August 31, 2010..... Tab 11
3. Recommendations on Camera System
4. Resident Candidate Forum Announcement October 19th – 7pm.
5. Operations & Amenity Update Tab 13
6. Amenity Center Improvements (Playgrounds, Volleyball Court etc)..... Tab 14
- 9:15 PM Supervisor Comments and Request**
- 9:30 PM Audience Comments on Non Agenda items**
- 9 :45 Ajournement**

We look forward to seeing you at the meeting. In the meantime, if you have any questions please do not hesitate to call us at (813) 873-7300.

Sincerely,



Brian K. Lamb,
District Manager

**LAKESIDE PLANTATION
COMMUNITY DEVELOPMENT DISTRICT**

August 12, 2010 Minutes of Meeting

Minutes of the Special and Regular Meeting

The special and regular meeting of the Lakeside Plantation Community Development District was held on Thursday, August 12, 2010 at 5:30 p.m., at the Lakeside Plantation Clubhouse, 2200 Plantation Boulevard, North Port, Florida 34289.

1. CALL TO ORDER

Mr. Lamb called the special and regular meeting of the Board of Supervisors of the Lakeside Plantation Community Development District to order on Thursday, August 12, 2010 at 5:30 p.m.

- A. Overview of Meeting Guidelines
- B. Roll Call
- C. Pledge of Allegiance

Board Members Present and constituting a quorum:

Bill Capozzi	Chairman
Bob Babik	Vice-Chair
Ron Bock	Assistant Secretary
Gwynne Balson	Assistant Secretary
David Polk	Assistant Secretary

Staff members present:

Brian Lamb	District Manager, District Management Services, LLC
Peter Altman	District Manager, District Management Services, LLC

2. PUBLIC HEARING:

- A. Fiscal Year 2011 Budget Public Hearing

MOTION TO:	Open the public hearing on FY2011 Proposed Operating Budget
MADE BY:	Supervisor Balson
SECONDED BY:	Supervisor Capozzi
DISCUSSION:	None further
RESULT:	Called to Vote: motion PASSED 5/0 - Motion passed unanimously (0:03:09)

Mr. Lamb informed the Board that there has been no overall change in the budget with the exception of the landscaping services line item which provides for 3% increase to coincide with the contractual services agreement which will be moved from the contingency fund.

- A resident addressed the Board regarding the proposed FY2011 budget with respect to interest income and wanted to know why the earnings are dropping by \$1270; she also addressed the line item for legal fees; and clubhouse renovations/improvements. Clarification of all the lines item expenditures were explained in detail by the Board.
- A resident addressed the Board regarding the proposed FY2011 budget with respect to the activities/events revenue line item and personnel hours' line item. This resident also addressed the taxes for ad valorem line item and the reserve account line item and uninsured reserve account

49 line item. Clarifications of all the line item expenditures were explained in detail by
50 Management. This resident also requested to see a designated line item for the future repair of
51 the roads.

- 52
- 53 • A resident addressed the Board regarding the proposed FY2011 budget with respect to the
54 discretionary expenditure for the clubhouse and feels there needs to policies and procedures in
55 place for such expenditures and a cap for such expenditures in the amount of \$20,000.
56
 - 57 • A resident addressed the Board regarding the way the State set up Community Development
58 Districts and addressed what he feels to be an abuse of the use of the contingency funds and
59 would like to limit the capability of the Board to do so in the future.
60
 - 61 • A resident addressed the Board regarding the reserve funds; and wanted to know if the CDD had
62 a reserve account identified the proposed budget. It was clarified the reserve study information
63 will be available at the next Board meeting.
64
 - 65 • Supervisor Balson requested the addition clubhouse renovations as a line item.
66
 - 67 • Supervisor Polk expressed the use of contingencies and moved to rename line item uninsurable
68 asset reserve fund or emergency reserve fund.
69

70 MOTION TO: Rename the contingency fund line item to uninsurable
71 asset reserve fund.
72 MADE BY: Supervisor Polk
73 SECONDED BY: Supervisor Capozzi
74 DISCUSSION: None further
75 RESULT: Called to Vote: motion PASSED
76 5/0 - Motion passed unanimously (0:40:09)

77

78 MOTION TO: Close the public hearing on FY2011 Proposed Operating
79 Budget
80 MADE BY: Supervisor Balson
81 SECONDED BY: Supervisor Bock
82 DISCUSSION: None further
83 RESULT: Called to Vote: motion PASSED
84 5/0 - Motion passed unanimously (0:41:35)

85
86 B. Consideration of Resolution 2010-11 FY2011 Budget Adoption

87 The Board reviewed Resolution 2010-11 the annual appropriation resolution of the Lakeside Plantation
88 Community Development District relating to the annual appropriations and adopting the budget for the
89 fiscal year beginning October 1, 2010 and ending September 30, 2011. Mr. Lamb reiterated there has
90 been no overall change in the budget with the exception of the landscaping services line item which
91 provides for 3% increase to coincide with the contractual services agreement which will be moved from
92 the contingency fund which has been renamed uninsurable asset reserve.
93

94 MOTION TO: Approve Resolution 2010-11 the annual appropriation
95 resolution of the Lakeside Plantation Community
96 Development District relating to the annual appropriations
97 and adopting the budget for the fiscal year beginning
98 October 1, 2010 and ending September 30, 2011.
99 MADE BY: Supervisor Capozzi
100 SECONDED BY: Supervisor Bock
101 DISCUSSION: None further
102 RESULT: Called to Vote: motion PASSED
103 5/0 - Motion passed unanimously (0:43:22)

104
105 C. Consideration of Resolution 2010-12 FY2011 Budget Assessment

106 The Board reviewed Resolution 2010-12 a resolution of the Board of Supervisors of the Lakeside
107 Plantation Community Development District imposing special assessments and certifying an assessment
108 roll; providing a severability clause; and providing an effective date.
109

110 MOTION TO: Approve Resolution 2010-12 a resolution of the Board of
111 Supervisors of the Lakeside Plantation Community
112 Development District imposing special assessments and
113 certifying an assessment roll; providing a severability
114 clause; and providing an effective date.
115 MADE BY: Supervisor Balson
116 SECONDED BY: Supervisor Bock
117 DISCUSSION: None further
118 RESULT: Called to Vote: motion PASSED
119 5/0 - Motion passed unanimously (0:41:35)

120
121 D. Consideration of Resolution 2010-13 Spending Authority

122 The Board reviewed Resolution 2010-13 a resolution of the Board of Supervisors of Lakeside Plantation
123 Community Development District authorizing the disbursement of funds for payment of certain
124 continuing expenses without prior approval of the Board of Supervisors; authorizing the disbursement of
125 funds for payment of certain non-continuing expenses without prior approval of the Board of Supervisors;
126 providing for a monetary threshold; and providing for an effective date. This resolution was not
127 considered at this meeting and will be up for discussion at a later date.
128

129 E. Consideration of Resolution 2010-14 FY2010/2011 Annual Meeting Schedule

130 The Board reviewed Resolution 2010-14 a resolution of the Board of Supervisors of the Lakeside
131 Plantation Community Development District designating date, time and location for regular meetings of
132 the Board of Supervisors and providing for an effective date. It was noted the meetings are currently
133 scheduled for the fourth Thursday of every month. Discussion ensued regarding the dates of the
134 meetings. It was recommended to move the meetings to the second Thursday of the month. The meeting
135 dates for the 2nd Thursday of every month are as follows:

136 October 14, 2010
137 November 11, 2010
138 December 9, 2010

139 January 13, 2011
140 February 10, 2011
141 March 10, 2011
142 April 14, 2011
143 May 12, 2011
144 June 9, 2011
145 July 14, 2011
146 August 11, 2011
147 September 8, 2011

148 Meetings will convene at 7:00 p.m. at the Lakeside Plantation Clubhouse, located at 2200 Plantation
149 Boulevard, North Port, Florida 34289.
150

151	MOTION TO:	Approve Resolution 2010-14 a resolution of the Board of
152		Supervisors of the Lakeside Plantation Community
153		Development District designating date, time and location
154		for regular meetings of the Board of Supervisors and
155		providing for an effective date and amending the exhibit to
156		reflect meetings to be held on the 2 nd Thursday of every
157		month.
158	MADE BY:	Supervisor Balson
159	SECONDED BY:	Supervisor Bock
160	DISCUSSION:	None further
161	RESULT:	Called to Vote: motion PASSED
162		5/0 - Motion passed unanimously (0:41:35)

163
164 **3. BUSINESS ITEMS:**

165 A. Imagine School Tract Three Drainage Easement
166 Mr. Neal addressed the Board regarding the need to modify the drainage, filling a pond and moving water
167 to another site. Mr. Neal also addressed the landscaping buffer and drainage easement. Mr. Neal
168 continued to explain the costs associated and advised that the District Engineer, the City, and SWFMD
169 are all in agreement to modification and that there will be no adverse affect to the District. It was noted
170 that all costs incurred the District Engineer will be reimbursed by Neil Communities.

171
172 Mr. Lamb presented the Board with the “Release of Drainage Easement;” the “Release of Use
173 Restriction;” and the “Relocation of Drainage Easement.” (Exhibit A). It was questioned who would be
174 responsible for maintaining the equalizer pipe. It was clarified that it will be maintained by the City
175 because it is not considered to be District property.
176

177	MOTION TO:	Approve the Release of Drainage Easement, Release of
178		Use Restriction and Relocation of Drainage Easement with
179		approval by the Chairman
180	MADE BY:	Supervisor Polk
181	SECONDED BY:	Supervisor Babik
182	DISCUSSION:	None further
183	RESULT:	Called to Vote: motion PASSED

184
185
186
187
188
189
190
191
192
193
194
195
196
197
198
199
200
201
202
203
204
205
206
207
208
209
210
211
212
213
214
215
216
217
218
219
220
221
222
223
224
225
226
227
228
229

5/0 - Motion passed unanimously (0:59:47)

Mr. Lamb addressed the Board regarding the Fire Station Parcel and stated that the City of North Port has exercised the release of reverter with respect to the fire station parcel. The fire station parcel is no longer the property of the City it is now the property of the Lakeside Plantation Community Development District.

4. AUDIENCE COMMENTS

- A resident addressed the Board about having a resident forum prior to the November election. This resident also addressed the library and expressed an interest in expanding the children’s book section and requested \$100 to purchase new books for the children’s section. This resident also addressed the capital assets. Discussion ensued regarding the Board members who are running for election and the Florida Sunshine Law.
- A resident addressed the Board regarding collecting back packs for the homeless kids in North Port and reaching out to the community to inform them that the collection drive is taking place. This resident also addressed the Board regarding charging a fee for swim lessons. The portion of this resident’s comment was inaudible to the transcriptionist.
- A resident addressed the issue of the tennis pro charging a fee.
- A resident addressed the issue regarding the reserve account and Management and noted that the current Board is the only Board that took the initiative to get a reserve account and Management Company that is working for the benefit of the community.

5. BUSINESS ITEMS:

A. Review of Florida Sunshine Law

Mr. Altman provided an overview of the Florida Sunshine Law and elaborated on the maintenance of the public records for the District, advertising of public meetings and Supervisor restrictions with respect to commenting on issues related to Board action. Mr. Altman also provided examples of violations of the Florida Sunshine Law and elaborated on the consequences of any such violation.

B. Amenity Improvement Plan

Supervisor Babik updated the Board regarding the amenity improvement plan and noted the clubhouse flooring is almost complete, the arbors will be complete by next Tuesday. The District is still in the process of looking for playground equipment for the kids (shuffle board, volleyball, etc.). A presentation of the playground equipment and costs associated will be given at the next Board meeting.

C. Barriers – Sycamore

D. Fountain Report Update

Mr. Lamb updated the Board regarding the fountain and noted that several attempts have been made to try to get the fountains to work as is but due to the age of the fountain it will be necessary to tear the fountains down and start from the beginning in rebuilding the fountains. It was noted that the new pumps for the new fountains will be more energy efficient. A presentation of the fountains and costs associated will be given at the next Board meeting.

230 Mr. Lamb addressed the Board regarding the front entry monument and noted that Management is still
231 waiting for the proposals and expects the expense will less than originally indicated. A presentation of
232 the front entry monument proposals and costs associated will be given at the next Board meeting.
233

234 E. Funds for Library

235 *A resident addressed the Board regarding issues with the library; this resident's comment was inaudible*
236 *to the transcriptionist.*
237

238 F. Sales Tax

239 The Board reviewed the memo from the Steve Connolly, District Treasurer regarding "Sales Tax." The
240 District has been registered for Sales Tax purposes with effect from June 1, 2010. All applicable income
241 from October 1, 2009 has been declared resulting in a liability of \$671.25 as of June 30, 2010.
242

243 G. Signage bids

244 Previously discussed

245 H. General Matters of the District Management Services
246

247 **6. BUSINESS ADMINISTRATION:**

248 **A. Consideration of Minutes – June 24, 2010**

249 The Board reviewed the minutes of the Board of Supervisors for June 24, 2010. Line 17 and Line 19 were
250 amended by Supervisor Babik.
251

MOTION TO:	Approve the minutes of the Board of Supervisor for June 24, 2010 as amended
MADE BY:	Supervisor Bock
SECONDED BY:	Supervisor Polk
DISCUSSION:	None further
RESULT:	Called to Vote: motion PASSED 5/0 - Motion passed unanimously (1:41:03)

259
260 **7. STAFF REPORTS:**

261 A. District Counsel

262 Mr. Lamb informed the Board that Mr. Cox is no longer with Shumaker, Loop & Kendrick, LLP and that
263 Jeffrey Russell will serve at acting District Counsel for the Lakeside Plantation CDD. Supervisor Balson
264 expressed concern regarding the rate for Mr. Russell. Management will be responsible for reaffirming the
265 rates for Jeffery Russell, District Counsel and report back at the next meeting.
266

267 B. District Engineer

268 Mr. Lamb noted that the District Engineer has been working on the Neil Community requests; all the
269 District Engineer's costs associated will be reimbursed by Neil Communities.
270

271 C. District Manager Reports

272 i. Financial Reports period ending June 30, 2010.

273 The Board reviewed the financial reports period ending June 30, 2010. Management will be responsible
274 for providing a thorough review of the financial statements and recommendations at the next Board
275 meeting. The status of the update of vendor services was questioned. Management will be responsible
276 for providing a vendor services presentation at the next Board meeting.

277

278
279

280

281

282

283

284

MOTION TO:	Accept the financial statements period ending June 30, 2010.
MADE BY:	Supervisor Capozzi
SECONDED BY:	Supervisor Babik
DISCUSSION:	None further
RESULT:	Called to Vote: motion PASSED 5/0 - Motion passed unanimously (1:46:05)

285

286

8. SUPERVISOR COMMENTS AND REQUESTS:

287

288

289

290

291

292

293

294

295

296

297

- Supervisor Balson expressed concern regarding the reserve study and wanted to know why the District was not following the advice of Reserve Advisors. Supervisor Balson also addressed the access control with respect to having no keypad and no cameras.
- Supervisor Polk requested getting cameras as soon as the construction is complete and requested that the City take over Sycamore Drive. Management will be responsible for asking the City Manager/City Administration his opinion regarding the maintenance of the road (Sycamore Drive).
- Supervisor Capozzi requested adding sales tax to the rental fees.

298

299

300

301

302

303

MOTION TO:	Add sales tax to the rental fees
MADE BY:	Supervisor Capozzi
SECONDED BY:	Supervisor Babik
DISCUSSION:	None further
RESULT:	Called to Vote: motion PASSED 5/0 - Motion passed unanimously (1:51:31)

304

305

306

307

Discussion ensued regarding the pool attendant with respect to asking for pool passes from residents redundantly.

308

309

310

Supervisor Bock expressed concern with Sycamore Drive being turned over to the City. Discussion ensued regarding the maintenance of the Sycamore Drive.

311

AUDIENCE COMMENTS ON NON-AGENDA ITMES:

312

313

314

315

316

317

318

- A resident addressed Board regarding a huge problem with communication and wanted to get community involvement without violating the Sunshine Law with respect to the signage issue
- A resident addressed the Board regarding making a motion on discretionary income and wanted the Board to the address the community when expenses exceed \$15,000. This resident also addressed the Board regarding the signage issue.

- 319
- A resident addressed the Board regarding the Sunshine Law with respect voting Supervisor Balson off as Vice-Chairman of the Board of Supervisors and wanted to know why there was no discussion. This resident also wanted to know if the District had a reserve account.
- 320
321
322
- A resident addressed the Board requesting volunteers.
- 323
324
- A resident addressed the Board regarding the cameras and wanted to know if anyone has done a survey on how many people use the clubhouse and having the facilities open late in the evenings. This resident also addressed the issue having library hours. This resident also requested that the community get a copy of the financial statements.
- 325
326
327
328
329
- A resident addressed the Board regarding renovations to the clubhouse and not taking care of what we have i.e. the treadmill.
- 330
331
332
- A resident addressed the Board regarding upgrading the audio system.
- 333
334

335 Mr. Lamb and Mr. Altman elaborated on the questions of the residents with respect to the Sunshine Law,
336 the reserve study, the signage, communication and capital improvement expenditures. It was not that the
337 District does have a Reserve Account.
338

339 **10. ADJOURNMENT:**
340

MOTION TO:	Adjourn the meeting of the Board of Supervisor for Lakeside Plantation CDD for June 24, 2010.
MADE BY:	Supervisor Capozzi
SECONDED BY:	Supervisor Bock
DISCUSSION:	None further
RESULT:	Called to Vote: motion PASSED
	5/0 - Motion passed unanimously (2:24:05)

348

349 *These minutes were done in summary format.

350 *Each person who decides to appeal any decision made by the Board with respect to any matter
351 considered at the meeting is advised that person may need to ensure that a verbatim record of the
352 proceedings is made, including the testimony and evidence upon which such appeal is to be based.

353 Meeting minutes were approved at a meeting by vote of the Board of Supervisors at a publicly noticed
354 meeting held on _____.

355 _____
356 _____
357 **Signature**

Signature

358 _____
359 _____
360 **Printed Name**

Printed Name

361 _____
362 **Title:**
363 Secretary
364 Assistant Secretary

Title:
 Chairman
 Vice Chairman

365 _____
366 _____
367 _____
368 _____
369 _____
370 _____
371 _____
372 _____

Recorded by Records Administrator

Signature

Date

Exhibit "A"

Prepared by and return to:
Vogler Ashton, PLLC
2411 -A Manatee Ave. West
Bradenton, Florida 34205
(941)388-9400

RELEASE OF DRAINAGE EASEMENT

Do not use this space

This **RELEASE OF DRAINAGE EASEMENT** is made this 12th day of August, 2010, by **LAKESIDE PLANTATION COMMUNITY DEVELOPMENT DISTRICT**, a local unit of special purpose government established pursuant to Chapter 190, Florida Statutes, (referred to herein as the **ADistrict@**), whose mailing address is c/o District Management Services, LLC, 2002 N. Lois Avenue, Ste. 507, Tampa, Florida 33607, in favor of **HUNTINGTON NATIONAL REAL ESTATE INVESTMENTS, LLC**, a Florida limited liability company, and **WILL-RIDGE ASSOCIATES, LLC**, a New York limited liability company (collectively the "Grantee"), whose mailing address is c/o 8441 Cooper Creek Blvd., University Park, Florida 34201.

WITNESSETH:

WHEREAS, the District by dedication thereunto acquired the right to use an offsite drainage easement (the "Drainage Easement") over a portion of the Grantee's property identified as Tract "3" of the Plat of **LAKESIDE MARKETPLACE**, as shown in Plat recorded in Plat Book 42, Page 7, 7a-7c, of the Public Records of Sarasota County, Florida, (hereinafter "Tract 3"); and,

WHEREAS, District now desires to forever terminate, remise, release, quit-claim, exonerate and discharge the Drainage Easement, all as more fully set forth herein.

NOW THEREFORE, in consideration of the sum of Ten Dollars (\$10.00) and other good and valuable consideration, the receipt and sufficiency of which are hereby acknowledged, the District agrees as follows:

1. **Recitals.** That the above recitals are true and correct and are hereby incorporated herein.
2. **Release.** The District does hereby forever terminate, remise, and release all right, title and interest of the District in that certain Drainage Easement over Tract 3, and the District does hereby quit-claim and convey to Grantee, and its successors and assigns forever, all right, title and interest of District in that certain Drainage Easement previously retained by District over Tract 3, all as more particularly described as follows:

Tract "3" of the Plat of **LAKESIDE MARKETPLACE**, as shown in Plat recorded in Plat Book 42, Page 7, 7a-7c, of the Public Records of Sarasota County, Florida.

TO HAVE AND TO HOLD, the same, with appurtenances, unto the Grantee, and its successors and assigns, forever freed, exonerated and discharged of the Drainage Easement, and every part thereof.

IN WITNESS WHEREOF, the undersigned has executed this Release of Drainage Easement as of day, month and year first above written.

LAKESIDE PLANTATION COMMUNITY DEVELOPMENT DISTRICT,
a local unit of special purpose government, situated in Sarasota County, Florida

ATTEST:

Its: Secretary

Its: Assistant Secretary

By: _____

Its: Chairman

STATE OF FLORIDA
COUNTY OF SARASOTA

Sworn To and Subscribed before me this _____ day of _____, 2010, by _____, as Chairman of the **LAKESIDE PLANTATION COMMUNITY DEVELOPMENT DISTRICT**, a local unit of special purpose government established pursuant to Chapter 190, Florida Statutes, on behalf of the District, who is [] personally known to me, or who [] has produced _____ driver's license as identification.

My Commission Expires:

NOTARY PUBLIC - STATE OF FLORIDA
Print name: _____

Prepared by and return to:
 Vogler Ashton, PLLC
 2411 –A Manatee Ave. West
 Bradenton, Florida 34205
 (941)388-9400

RELEASE OF USE RESTRICTION

Do not use this space

This **RELEASE OF USE RESTRICTION** is made this 12th day of August, 2010, by **LAKESIDE PLANTATION COMMUNITY DEVELOPMENT DISTRICT**, a local unit of special purpose government established pursuant to Chapter 190, Florida Statutes, (referred to herein as the **District**), whose mailing address is c/o District Management Services, LLC, 2002 N. Lois Avenue, Ste. 507, Tampa, Florida 33607, in favor of **HUNTINGTON NATIONAL REAL ESTATE INVESTMENTS, LLC**, a Florida limited liability company, and **WILL-RIDGE ASSOCIATES, LLC**, a New York limited liability company (collectively the "Grantee"), whose mailing address is c/o 8441 Cooper Creek Blvd., University Park, Florida 34201.

WITNESSETH:

WHEREAS, the District by dedication thereunto acquired the right to use an offsite landscape buffer (the "Use Restriction") over a portion of the Grantee's property identified as Tract "3" of the Plat of **LAKESIDE MARKETPLACE**, as shown in Plat recorded in Plat Book 42, Page 7, 7a-7c, of the Public Records of Sarasota County, Florida, (hereinafter "Tract 3"); and,

WHEREAS, District now desires to forever terminate, remise, release, quit-claim, exonerate and discharge the Use Restriction, all as more fully set forth herein.

NOW THEREFORE, in consideration of the sum of Ten Dollars (\$10.00) and other good and valuable consideration, the receipt and sufficiency of which are hereby acknowledged, the District agrees as follows:

1. **Recitals.** That the above recitals are true and correct and are hereby incorporated herein.
2. **Release.** The District does hereby forever terminate, remise, release, quit-claim, exonerate and discharge from the Use Restriction, and any operation thereof, that certain land described as Tract 3, and more particularly described as follows:

Tract "3" of the Plat of **LAKESIDE MARKETPLACE**, as shown in Plat recorded in Plat Book 42, Page 7, 7a-7c, of the Public Records of Sarasota County, Florida.

And Grantee, its successors and assigns, are forever, freed, exonerated and discharged of and from the Use Restriction on Tract 3, and every part thereof.

IN WITNESS WHEREOF, the undersigned has executed this Release of Use Restriction as of day, month and year first above written.

LAKESIDE PLANTATION COMMUNITY DEVELOPMENT DISTRICT,
 a local unit of special purpose government, situated in Sarasota County, Florida

ATTEST:

 Its: Secretary

 Its: Assistant Secretary

By: _____
 Its: Chairman

STATE OF FLORIDA
COUNTY OF SARASOTA

Sworn To and Subscribed before me this _____ day of _____, 2010, by _____, as Chairman of the **LAKESIDE PLANTATION COMMUNITY DEVELOPMENT DISTRICT**, a local unit of special purpose government established pursuant to Chapter 190, Florida Statutes, on behalf of the District, who is [_____] personally known to me, or who [_____] has produced _____ driver's license as identification.

My Commission Expires:

NOTARY PUBLIC – STATE OF FLORIDA
 Print name: _____

This instrument prepared by and return to:
Vogler Ashton, PLLC
2411-A Manatee Ave. West
Bradenton, Florida 34205

ID # _____
=====SPACE ABOVE THIS LINE FOR RECORDING DATA=====

RELOCATION DRAINAGE EASEMENT

THIS GRANT of EASEMENT is made this 12th day of August, 2010, between **HUNTINGTON NATIONAL REAL ESTATE INVESTMENTS, LLC**, a Florida limited liability company, and **WILL-RIDGE ASSOCIATES, LLC**, a New York limited liability company (collectively the "Grantor"), whose mailing address is c/o 8441 Cooper Creek Blvd., University Park, Florida 34201, and **LAKESIDE PLANTATION COMMUNITY DEVELOPMENT DISTRICT**, a local unit of special purpose government established pursuant to Chapter 190, Florida Statutes, (referred to herein as the AGrantee@), whose mailing address is c/o District Management Services, LLC, 2002 N. Lois Avenue, Ste. 507, Tampa, Florida 33607.

WITNESSETH

That Grantor, for and in consideration of the sum of \$10.00 and other valuable consideration in hand paid, the receipt whereof is hereby acknowledged, has granted, bargained, sold and transferred, and by these presents does grant, bargain, sell and transfer unto the Grantee, **a non-exclusive easement for the expressed purpose of ingress, egress, and maintenance of surface and/or underground drainage**, and that the Grantee, for the duration of this easement, shall assume all responsibilities and liabilities which are normally inherent in the operation and maintenance of same, including any facilities to be located therein. Grantor reserves the right, in its discretion, to relocate or reconfigure said easement. Said easement shall be for property situated in the County of Sarasota, State of Florida, more particularly described as follows:

See legal description identified as EXHIBIT "A" attached hereto

It is further mutually agreed that this Easement shall be binding upon and shall inure to the benefit of the heirs, successors and assigns of the parties hereto.

TO HAVE AND TO HOLD the same together with all and singular the appurtenances thereunto belonging or in anywise appertaining, and all the estate, right, title, interest, lien, equity and claim whatsoever of the said Grantor, either in law or equity, to the only proper use, benefit and behalf of the said Grantee forever.

IN WITNESS WHEREOF, the undersigned has caused this Easement to be executed in their names as of the day and year indicated above.

Signed, sealed and delivered in
the presence of

**HUNTINGTON NATIONAL REAL ESTATE
INVESTMENTS, LLC**, a Florida limited liability
company

Print Name: _____

By: _____

Printed Name

Print Name: _____

Its:

**STATE OF FLORIDA
COUNTY OF MANATEE**

The foregoing instrument was acknowledged before me this _____ day of _____ 2010 by _____, as _____, of Huntington National Real Estate Investments, LLC, a Florida limited liability company, on behalf of the company, () who is personally known to me or () who has produced _____ as identification.

NOTARY PUBLIC Signature

Printed Name

WILL-RIDGE ASSOCIATES, LLC, a New York limited
liability company

Print Name: _____

By: _____

Printed Name

Print Name: _____

Its:

**STATE OF FLORIDA
COUNTY OF MANATEE**

The foregoing instrument was acknowledged before me this _____ day of _____ 2010 by _____, as _____, of Will-Ridge Associates, LLC, a New York limited liability company, on behalf of the company, () who is personally known to me or () who has produced _____ as identification.

NOTARY PUBLIC Signature

RESOLUTION 2010-14

A RESOLUTION OF THE BOARD OF SUPERVISORS OF THE LAKESIDE PLANTATION COMMUNITY DEVELOPMENT DISTRICT DESIGNATING DATE, TIME AND LOCATION FOR REGULAR MEETINGS OF THE BOARD OF SUPERVISORS AND PROVIDING FOR AN EFFECTIVE DATE HEREOF

WHEREAS, the Lakeside Plantation Community Development District (hereinafter the "District") is a local unit of special-purpose government created and existing pursuant to Chapter 190, Florida Statutes, being situated entirely within Sarasota County, Florida; and

WHEREAS, the District's Board of Supervisors (hereinafter the "Board"), is statutorily authorized to exercise the powers granted to the District, but has not heretofore met; and

WHEREAS, all meetings of the Board shall be open to the public and governed by the provisions of Chapter 286, Florida Statutes; and

WHEREAS, the Board is statutorily required to file annually, with the local governing authority and the Florida Department of Community Affairs, a schedule of its regular meetings.

NOW, THEREFORE, BE IT RESOLVED BY THE BOARD OF SUPERVISORS OF LAKESIDE PLANTATION COMMUNITY DEVELOPMENT DISTRICT THAT:

Section 1. Regular meetings of the Board of Supervisors of the Lakeside Plantation Community Development District, for the Fiscal Year of 2011, shall be held as provided on the schedule, which is attached hereto and made a part heretofore, as Exhibit A.

Section 2. In accordance with Section 189.417(1), Florida Statutes, the District's Secretary is hereby directed to file annually, with Sarasota and the Florida Department of Community Affairs, a schedule of the District's regular meetings.

Section 3. This Resolution shall become effective immediately upon its adoption.

PASSED AND ADOPTED THIS 12 DAY OF AUGUST, 2010.

LAKESIDE PLANTATION
COMMUNITY DEVELOPMENT DISTRICT

CHAIRMAN

ATTEST:



SECRETARY/ASSISTANT SECRETARY

EXHIBIT A

**BOARD OF SUPERVISORS MEETING DATES
LAKESIDE PLANTATION COMMUNITY DEVELOPMENT DISTRICT
BOARD OF SUPERVISORS REGULAR MEETING SCHEDULE**

FISCAL YEAR 2011

October 14, 2010 at 11:00 a.m.
November 11, 2010 at 11:00 a.m.
December 9, 2010 at 5:00 p.m.
January 13, 2011 at 11:00 a.m.
February 10, 2011 at 11:00 a.m.
March 10, 2011 at 5:00 p.m.
April 14, 2011 at 11:00 a.m.
May 12, 2011 at 5:00 p.m.
June 9, 2011 at 11:00 a.m.
July 14, 2011 at 11:00 a.m.
August 11, 2011 at 5:00 p.m.
September 8, 2011 at 11:00 a.m.

**Meetings will convene at 7:00 p.m. at the Lakeside Plantation Clubhouse, located at 2200 Plantation Boulevard,
North Port, Florida 34289.**

SHUMAKER, LOOP & KENDRICK, LLP
240 SOUTH PINEAPPLE AVENUE
P.O. BOX 49948
SARASOTA, FLORIDA 34230-6948

(941) 366-6660

FEDERAL TAX NO. 34-4439491

April 22, 2010

Billed through 03-31-10

Bill number 223246

Lakeside Plantation Community Development District
 Chairman
 2200 Plantation Blvd.
 North Port, FL 34289

I.D. L00243-137443 WPC

RE: Dispute with Former Employee - Carrie Greus

DISTRICT ADMINISTRATOR APPROVAL _____
 FUND TYPE _____ O&M _____ C&A _____
 FUND CODE _____
 GL CODE _____
 OBJECT CODE _____
 DATE ENTERED _____
 CHECK NUMBER _____

Current Fees	9,819.50	
Courtesy Discount	<1,000.00>	
Total Due for this Bill		8,819.50
Total Due for this Matter		----- \$ 8,819.50 =====

REVISED

DISTRICT ADMINISTRATOR APPROVAL _____
 FUND TYPE _____ O&M _____ C&A _____
 FUND CODE _____
 GL CODE _____
 OBJECT CODE 51400
 DATE ENTERED 5/07
 CHECK NUMBER _____

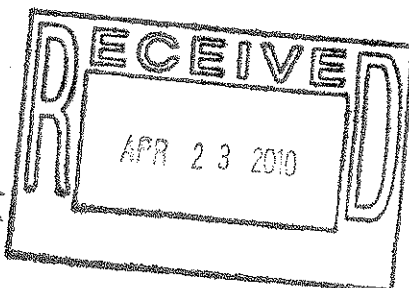

* * PLEASE REMIT THIS PAGE WITH YOUR PAYMENT * *

PAYMENT DUE WITHIN 30 DAYS.

Invoices remaining unpaid 30 days after date of invoice will be charged a late payment charge of 1.5% per month.

SHUMAKER, LOOP & KENDRICK, LLP

Bill number 223246

Page 2

Lakeside Plantation Community Development District
 Re: Dispute with Former Employee - Carrie Greus

I.D. L00243-137443 WPC

FOR PROFESSIONAL SERVICES RENDERED

DATE	ATTY	DESCRIPTION OF SERVICES	HOURS	RATE/HR	AMOUNT
03-04-10	WPC	Review letter from Sensenig law firm regarding preservation of client documents and records for prospective C. Greus lawsuit; office conference with J. Collier regarding the same; telephone conferences with all CDD Supervisors regarding litigation hold.	1.90	175.00	332.50
03-04-10	JAC	Office conference with W. Cox regarding letter from attorney for C. Greus and strategy discussions; review letter from C. Sensenig regarding C. Greus demand letter and threatened litigation; prepare detailed litigation preservation letter.	0.80	250.00	200.00
03-05-10	JAC	Telephone conversation with B. Capozzi regarding C. Greus; review e-mails and documents from B. Capozzi regarding C. Greus; prepare e-mail to B. Capozzi regarding documents; review demand letter from C. Greus regarding ELSA issues; review e-mail from B. Lamb regarding telephone conference; office conference with W. Cox regarding receipt and review of demand letter from C. Greus, strategy discussions, case overview, and documentation needed.	1.00	250.00	250.00
03-05-10	WPC	Finalize and e-mail C. Greus litigation hold letter to CDD Board and District Manager; office conference with J. Collier regarding potential C. Greus claims.	0.80	175.00	140.00
03-05-10	WPC	Review settlement offer letter from Attorney for C. Greus; office			

SHUMAKER, LOOP & KENDRICK, LLP

Bill number 223246

Page 3

Lakeside Plantation Community Development District
 Re: Dispute with Former Employee - Carrie Greus

I.D. L00243-137443 WPC

FOR PROFESSIONAL SERVICES RENDERED

DATE	ATTY	DESCRIPTION OF SERVICES	HOURS	RATE/HR	AMOUNT
		conference with J. Collier regarding the same; e-mail to and from B. Lamb regarding the same.	1.20	175.00	210.00
03-08-10	JAC	Review e-mails from B. Lamb regarding Greus matter; prepare e-mail to B. Lamb regarding Greus matter; review draft letter to C. Sensenig; office conference with W. Cox regarding letter to Sensenig.	0.30	250.00	75.00
03-08-10	WPC	Review and respond to e-mail from B. Lamb regarding next steps on C. Greus employment claim matter; draft response letter to attorney C. Sensenig regarding March 2, 2010, offer of settlement letter regarding C. Greus claim.	1.50	175.00	262.50
03-09-10	JAC	Office conference with W. Cox regarding Greus matter and litigation preparation strategy discussions.	0.20	250.00	50.00
03-10-10	JAC	Review e-mails from B. Lamb re: C. Greus and resident issues; telephone conversation with B. Lamb, D. Sullivan, and W. Cox re: C. Greus and strategy discussions; office conference with W. Cox re: defense strategy discussions; review and revise letter to C. Sensenig re: response to demand letter; review e-mail re: list of property taken by C. Greus; begin review of documentation and e-mails from D. Sullivan re: C. Greus.	2.00	250.00	500.00
03-10-10	WPC	Preparation for conference call with B. Lamb regarding pending CDD matters; including C. Greus matter; conference call with B.			

SHUMAKER, LOOP & KENDRICK, LLP

Bill number 223246

Page 4

Lakeside Plantation Community Development District
 Re: Dispute with Former Employee - Carrie Greus

I.D. L00243-137443 WPC

FOR PROFESSIONAL SERVICES RENDERED

DATE	ATTY	DESCRIPTION OF SERVICES	HOURS	RATE/HR	AMOUNT
		Lamb and J. Collier regarding the same; revise and finalize response letter to counsel for C. Greus regarding offer of settlement; review e-mail from B. Lamb regarding proposed property removed from District by C. Greus.	1.90	175.00	332.50
03-10-10	WPC	Further legal analysis to ensure compliance with litigation hold requirements for C. Greus matter; review documents related to potential C. Greus claim to evaluate merits of potential claims.	0.70	175.00	122.50
03-11-10	WPC	Office conference with J. Collier to discuss strategy on C. Greus matter.	0.20	175.00	35.00
03-11-10	WPC	Telephone conference with C. Sensenig, attorney for C. Greus, regarding offer of settlement.	0.30	175.00	52.50
03-12-10	WPC	Review e-mail from D. Sullivan regarding Employee Handbook issue.	0.30	175.00	52.50
03-15-10	JAC	Office conference with W. Cox regarding C. Sensenig and Greus matter; review letter from M. Wolf's attorney; review letter from D. Sullivan regarding termination of District employees; receipt and review of employee handbook from D. Sullivan.	0.60	250.00	150.00
03-15-10	WPC	Office conference with J. Collier regarding status and evaluation of C. Greus claim.	0.20	175.00	35.00
03-16-10	JAC	Review timesheets regarding C. Greus; review pay records regarding C. Greus; review personnel file regarding C. Greus;			

SHUMAKER, LOOP & KENDRICK, LLP

Bill number 223246

Page 5

Lakeside Plantation Community Development District
 Re: Dispute with Former Employee - Carrie Greus

I.D. L00243-137443 WPC

FOR PROFESSIONAL SERVICES RENDERED

DATE	ATTY	DESCRIPTION OF SERVICES	HOURS	RATE/HR	AMOUNT
		review meeting minutes regarding C. Greus; prepare FLSA analysis regarding hours worked and amounts paid; numerous e-mails to and from D. Sullivan regarding gathering of information to respond to Sensenig letter; prepare detailed letter in response to demand letter from C. Sensenig regarding C. Greus.	6.60	250.00	1,650.00
03-16-10	WPC	E-mails from J. Collier, D. Sullivan, and B. Lamb regarding evaluation of C. Greus claims; office conferences with J. Collier regarding the same to discuss strategy.	1.00	175.00	175.00
03-17-10	JAC	Continued review of hundreds of pages of documents regarding Greus matter; prepare detailed response to demand letter from C. Sensenig; telephone conversation with B. Lamb, D. Sullivan, and W. Cox regarding strategy discussions on responding to Greus demand letter; e-mails to and from B. Lamb regarding Greus matter; e-mails to and from D. Sullivan regarding Greus matter; review Board meeting minutes regarding Greus matter; prepare e-mail to B. Capozzi regarding Greus matter; initiated telephone call to B. Capozzi per B. Lamb regarding response to demand letter; received telephone call from B. Capozzi regarding response to demand letter and discussions regarding Greus matter; office conference with W. Cox regarding strategy discussions on response in Greus matter.	5.00	250.00	1,250.00
03-17-10	WPC	Prepare for conference call with B. Lamb to discuss C. Greus and B.			

SHUMAKER, LOOP & KENDRICK, LLP

Bill number 223246

Page 6

Lakeside Plantation Community Development District
 Re: Dispute with Former Employee - Carrie Greus

I.D. L00243-137443 WPC

FOR PROFESSIONAL SERVICES RENDERED

DATE	ATTY	DESCRIPTION OF SERVICES	HOURS	RATE/HR	AMOUNT
		Lamb threatened litigation; review related documents e-mailed by D. Sullivan and J. Collier; office conference with J. Collier to discuss strategy.	2.20	175.00	385.00
03-18-10	JAC	Review documents regarding Greus matter; office conference with W. Cox regarding confidentiality issues and upcoming Board meeting.	0.30	250.00	75.00
03-18-10	WPC	Follow-up telephone conferences with B. Lamb and J. Collier regarding documents to include in CDD Board agenda packet; review documents for inclusion.	0.70	175.00	122.50
03-22-10	JAC	Review demand letter from C. Sensenig; review response to demand letter from C. Sensenig; telephone conversation with C. Sensenig regarding FLSA matter involving Carrie Greus.	0.50	250.00	125.00
03-24-10	JAC	Office conference with W. Cox regarding conversation with C. Sensenig, status update, and strategy discussions; review file regarding memo and Board meeting; prepare memo to W. Cox regarding outline of status of case for report to Board.	1.20	250.00	300.00
03-24-10	WPC	Telephone conference and e-mail with J. Collier regarding status and strategy for C. Greus claims	0.40	175.00	70.00
03-25-10	JAC	Office conference with W. Cox regarding Board meeting, FLSA issues, and various Greus matters.	0.20	250.00	50.00
03-25-10	WPC	Further preparation and review of documents for CDD Board meeting; office conference with J. Collier			

SHUMAKER, LOOP & KENDRICK, LLP

Bill number 223246

Page 7

Lakeside Plantation Community Development District
 Re: Dispute with Former Employee - Carrie Greus

I.D. L00243-137443 WPC

FOR PROFESSIONAL SERVICES RENDERED

DATE	ATTY	DESCRIPTION OF SERVICES	HOURS	RATE/HR	AMOUNT
		and meeting with B. Lamb regarding the same.	1.70	175.00	297.50
03-26-10	JAC	Telephone conversation with C. Sensenig regarding settlement discussions and scope of release; office conference with W. Cox regarding Board meeting and Board's settlement offer; research re: release of worker's compensation claims; begin preparation of settlement agreement regarding C. Greus matter.	2.00	250.00	500.00
03-26-10	WPC	Follow-up e-mails to and from B. Lamb and J. Collier; office conferences with J. Collier regarding C. Greus matter and strategy for release document.	0.80	175.00	140.00
03-29-10	JAC	Prepare Settlement Agreement regarding C. Greus; review and revise letter to B. Lamb regarding settlement status and scope of waiver; office conference with W. Cox regarding letter to B. Lamb and strategy discussions.	0.90	250.00	225.00
03-29-10	JBC	Receipt and review e-mail; office conference with J. Collier; office conference with W. Cox; office conference with A. Abate; telephone conference with W. Capozzi.	3.00	310.00	930.00
03-29-10	JBC	Letter to B. Lamb.	0.20	310.00	62.00
03-30-10	JAC	Prepare Separation Agreement for C. Greus; prepare e-mail to B. Lamb regarding additional information needed for separation agreement; telephone conversation with B. Lamb regarding additional			

SHUMAKER, LOOP & KENDRICK, LLP

Bill number 223246

Page 8

Lakeside Plantation Community Development District
 Re: Dispute with Former Employee - Carrie Greus

I.D. L00243-137443 WPC

FOR PROFESSIONAL SERVICES RENDERED

DATE	ATTY	DESCRIPTION OF SERVICES	HOURS	RATE/HR	AMOUNT
		information needed for separation agreement and strategy discussions; office conference with W. Cox regarding status update; prepare e-mail to C. Sensenig regarding withdrawal of offer.	1.50	250.00	375.00
03-30-10	WPC	Follow-up office conference and e-mail with J. Collier regarding C. Greus settlement negotiations.	0.30	175.00	52.50
03-31-10	JAC	Telephone conversation with B. Capozzi regarding various Carrie Greus matters; prepare e-mail to B. Lamb regarding Greus matter and conversation with B. Capozzi; telephone conversation with C. Sensenig regarding withdrawal of settlement offer and timesheets/pay records; office conference with W. Cox regarding strategy discussions and status update.	0.80	250.00	200.00
03-31-10	WPC	Office conference with J. Collier regarding April CDD Board meeting and C. Greus matter.	0.20	175.00	35.00
Total Fees for this Matter			43.40 hrs	\$	9,819.50

BILLING SUMMARY

Jennifer B. Compton	JBC	3.20 hrs	\$ 310.00 /hr	992.00
Jason A. Collier	JAC	23.90 hrs	\$ 250.00 /hr	5,975.00
William P. Cox	WPC	16.30 hrs	\$ 175.00 /hr	2,852.50
TOTAL FEES				9,819.50
TOTAL CHARGES FOR THIS BILL				9,819.50
COURTESY DISCOUNT				<1,000.00>
TOTAL DUE FOR THIS BILL				8,819.50

SHUMAKER, LOOP & KENDRICK, LLP

Bill number 223246

Page 9

Lakeside Plantation Community Development District
Re: Dispute with Former Employee - Carrie Greus

I.D. L00243-137443 WPC

TOTAL DUE FOR THIS MATTER

\$ 8,819.50
=====

SHUMAKER, LOOP & KENDRICK, LLP
240 SOUTH PINEAPPLE AVENUE
P.O. BOX 49948
SARASOTA, FLORIDA 34230-6948

(941) 366-6660

FEDERAL TAX NO. 34-4439491

May 26, 2010

Billed through 04-30-10

Bill number 227962

I.D. L00243-137443 JAC

Lakeside Plantation Community Development District
Attn: Chairman
2200 Plantation Blvd.
North Port, FL 34289

RE: Dispute with Former Employee - Carrie Greus

Previous Balance		8,819.50
Current Fees	8,367.00	
Current Disbursements	38.00	
Total Due for this Bill		8,405.00
Total Due for this Matter		<u>\$ 17,224.50</u>

**** PLEASE REMIT THIS PAGE WITH YOUR PAYMENT ****

PAYMENT DUE WITHIN 30 DAYS.

Invoices remaining unpaid 30 days after date of invoice will be charged a late payment charge of 1.5% per month.

SHUMAKER, LOOP & KENDRICK, LLP

Bill number 227962

Page 2

Lakeside Plantation Community Development District
 Re: Dispute with Former Employee - Carrie Greus

I.D. L00243-137443 JAC

FOR PROFESSIONAL SERVICES RENDERED

DATE	ATTY	DESCRIPTION OF SERVICES	HOURS	RATE/HR	AMOUNT
04-02-10	JAC	Review e-mail from C. Sensenig regarding FLSA claims, hours allegedly worked "off the clock", and additional allegations; review documents produced by C. Sensenig regarding C. Greus schedules and wage claims; compare documents produced by C. Sensenig against existing time sheets and pay records; office conference with W. Cox regarding e-mail and documentation provided by C. Sensenig; research statute and caselaw regarding scope of waiver/release of claims in worker's compensation arena; e-mail to B. Lamb regarding Sensenig e-mail.	2.90	250.00	725.00
04-02-10	JBC	Office conference with J. Collier. (No Charge)	0.20	0.00	0.00
04-02-10	JBC	Office conference with J. Collier regarding Workers' Comp. settlement; research same.	1.20	310.00	372.00
04-02-10	WPC	Review e-mail from C. Sensenig and attached C. Greus timesheets supporting C. Greus' allegations; review e-mail from E. Lewis regarding conduct of Chair B. Capozzi.	0.70	175.00	122.50
04-03-10	JBC	Continue research on Workers' Comp. release.	1.50	310.00	465.00
04-05-10	JAC	Research regarding scope of waiver and worker's compensation benefits issue. (No Charge)	0.50	0.00	0.00
04-05-10	JBC	Finish research regarding Workers' Comp. release; office conference with J. Collier. (No Charge)	0.80	0.00	0.00

SHUMAKER, LOOP & KENDRICK, LLP

Bill number 227962

Page 3

Lakeside Plantation Community Development District
 Re: Dispute with Former Employee - Carrie Greus

I.D. L00243-137443 JAC

FOR PROFESSIONAL SERVICES RENDERED

DATE	ATTY	DESCRIPTION OF SERVICES	HOURS	RATE/HR	AMOUNT
04-07-10	JAC	Research scope of waiver/release issues regarding worker's compensation issues; telephone calls to and from C. Sensenig regarding Greus matter. (No Charge)	0.40	0.00	0.00
04-11-10	WPC	Review audio recording of previous CDD meeting (No Charge).	0.50	0.00	0.00
04-12-10	JAC	Office conference with W. Cox regarding C. Greus and upcoming Board meeting; prepare e-mail to B. Lamb regarding C. Greus and upcoming Board meeting. (No Charge)	0.30	0.00	0.00
04-12-10	WPC	Office conference with J. Collier in preparation for upcoming CDD Board meeting and C. Greus matter. (No Charge)	0.40	0.00	0.00
04-15-10	JAC	Office conference with W. Cox regarding request to draft language for Agenda for upcoming Board meeting. (No Charge)	0.10	0.00	0.00
04-15-10	WPC	Telephone conference and e-mail with V. Weinkauff, DMS, regarding attorney's report for April CDD meeting agenda.	0.30	175.00	52.50
04-16-10	JAC	Prepare e-mail to V. Weinkauff regarding description of C. Greus matter for agenda for upcoming Board meeting; review e-mails from V. Weinkauff regarding Greus matter; prepare brief memorandum to V. Weinkauff and B. Lamb regarding more detailed description of C. Greus matter in advance of upcoming Board meeting; office conference with W. Cox regarding C. Greus matter and			

SHUMAKER, LOOP & KENDRICK, LLP

Bill number 227962

Page 4

Lakeside Plantation Community Development District
 Re: Dispute with Former Employee - Carrie Greus

I.D. L00243-137443 JAC

FOR PROFESSIONAL SERVICES RENDERED

DATE	ATTY	DESCRIPTION OF SERVICES	HOURS	RATE/HR	AMOUNT
		upcoming Board meeting; review file regarding dialogue with C. Greus' attorney.	1.20	250.00	300.00
04-16-10	WPC	Assist J. Collier in preparing C. Greus matter summary for CDD Board agenda packet.	0.40	175.00	70.00
04-19-10	JAC	Office conference with W. Cox regarding Greus matter strategy discussions, upcoming Board meeting, and status update; telephone call to B. Lamb regarding upcoming Board meeting. (No Charge)	0.30	0.00	0.00
04-20-10	JAC	Telephone conversation with C. Sensenig re: settlement discussions; e-mails to and from B. Lamb re: upcoming Board meeting; review notes re: outstanding items and preparation for conference call with B. Lamb; office conference with W. Cox regarding Greus matter and strategy discussions; review Separation Agreement regarding outstanding information needed and provisions to discuss with Board; review Agenda for upcoming Board meeting.	1.50	250.00	375.00
04-20-10	WPC	Further preparation for April CDD Board meeting; e-mails to and from B. Lamb regarding the same; review agenda for CDD Board meeting.	0.80	175.00	140.00
04-21-10	WPC	Further preparation for CDD Board meeting; conference call with B. Lamb, D. Sullivan, and J. Collier regarding CDD Board presentation.	1.80	175.00	315.00
04-21-10	JAC	Telephone conference with B. Lamb, D. Sullivan, and W. Cox regarding			

SHUMAKER, LOOP & KENDRICK, LLP

Bill number 227962

Page 5

Lakeside Plantation Community Development District
 Re: Dispute with Former Employee - Carrie Greus

I.D. L00243-137443 JAC

FOR PROFESSIONAL SERVICES RENDERED

DATE	ATTY	DESCRIPTION OF SERVICES	HOURS	RATE/HR	AMOUNT
		status update, strategy discussions, upcoming Board meeting, and report to Board on Greus matter; e-mails to and from B. Lamb regarding Board meeting and report to Board; office conference with W. Cox regarding report to Board; review file regarding preparation of detailed report to Board at upcoming meeting; prepare detailed report to Board regarding Greus matter for upcoming Board meeting.	4.90	250.00	1,225.00
04-22-10	JAC	Review file regarding preparation of material for Board meeting; prepare detailed summary report to Board regarding Greus matter and recommendations; telephone conversation with B. Lamb regarding Board meeting and strategy discussions; office conference with W. Cox regarding Board meeting and strategy discussions; review proposed resolution regarding attorneys' fees issues; travel to and from North Port for Board meeting; attend and present at Board meeting.	8.30	250.00	2,075.00
04-22-10	JBC	Office conference with J. Collier regarding health insurance reimbursement. (No Charge)	0.20	0.00	0.00
04-22-10	WPC	Further preparation for CDD Board meeting; office conferences with J. Collier regarding the same.	0.80	175.00	140.00
04-22-10	WPC	Telephone conferences with D. Sullivan regarding C. Greus matter invoice; consider and analyze courtesy discount request from District Manager on invoice;			

SHUMAKER, LOOP & KENDRICK, LLP

Bill number 227962

Page 6

Lakeside Plantation Community Development District
 Re: Dispute with Former Employee - Carrie Greus

I.D. L00243-137443 JAC

FOR PROFESSIONAL SERVICES RENDERED

DATE	ATTY	DESCRIPTION OF SERVICES	HOURS	RATE/HR	AMOUNT
		office conference with J. Collier regarding the same. (No Charge)	1.00	0.00	0.00
04-22-10	WPC	Travel to and from CDD Board meeting; participate in CDD Board meeting. (No Charge).	4.00	0.00	0.00
04-23-10	WPC	Office conference with J. Collier regarding settlement agreement with C. Greus.	0.20	175.00	35.00
04-23-10	JAC	Prepare Settlement Agreement; telephone call to C. Sensenig regarding Settlement Agreement; prepare e-mail to D. Sullivan regarding information for Greus Settlement Agreement.	1.70	250.00	425.00
04-26-10	WPC	Review proposed Greus release document; telephone conferences with J. Collier regarding additional terms requested by attorney for C. Greus and C. Sensenig.	0.90	175.00	157.50
04-26-10	JAC	Prepare detailed Settlement Agreement; e-mails to and from B. Lamb regarding settlement agreement; office conference with W. Cox regarding settlement agreement; review e-mail from D. Sullivan regarding information for waiver in settlement agreement; telephone conversation with C. Sensenig regarding settlement agreement; e-mails to and from C. Sensenig regarding settlement offer and settlement discussions, items for settlement agreement, and proposed revisions to settlement agreement.	3.00	250.00	750.00
04-27-10	JAC	E-mails to and from B. Lamb regarding Greus matter, proposed			

SHUMAKER, LOOP & KENDRICK, LLP

Bill number 227962

Page 7

Lakeside Plantation Community Development District
 Re: Dispute with Former Employee - Carrie Greus

I.D. L00243-137443 JAC

FOR PROFESSIONAL SERVICES RENDERED

DATE	ATTY DESCRIPTION OF SERVICES	HOURS	RATE/HR	AMOUNT
	revisions to Settlement Agreement, and strategy discussions; prepare revisions to Settlement Agreement; e-mails to and from C. Sensenig regarding Settlement Agreement, settlement discussions, and proposed revisions; telephone conversation with C. Sensenig regarding Settlement Agreement and proposed revisions.	2.00	250.00	500.00
04-27-10	WPC Review comments on release documents from C. Sensenig; office conference and related e-mails with J. Collier regarding the same.	0.70	175.00	122.50
04-30-10	JAC Telephone call from C. Sensenig regarding agreement status; review e-mails from C. Sensenig regarding agreement; prepare e-mail to C. Sensenig regarding agreement; prepare e-mail to B. Lamb regarding agreement. (No Charge)	0.20	0.00	0.00
		-----	-----	-----
Total Fees for this Matter		43.70 hrs	\$	8,367.00

DISBURSEMENTS

04-29-10	Travel to; Reimb. mileage to/from Sarasota/NorthPort; Jason A. Collier			38.00

Total Disbursements for this Matter				\$ 38.00

BILLING SUMMARY

Jennifer B. Compton	JBC	1.20 hrs	\$ 0.00 /hr	0.00
Jennifer B. Compton	JBC	2.70 hrs	\$ 310.00 /hr	837.00
Jason A. Collier	JAC	1.80 hrs	\$ 0.00 /hr	0.00
Jason A. Collier	JAC	25.50 hrs	\$ 250.00 /hr	6,375.00
William P. Cox	WPC	5.90 hrs	\$ 0.00 /hr	0.00
William P. Cox	WPC	6.60 hrs	\$ 175.00 /hr	1,155.00

SHUMAKER, LOOP & KENDRICK, LLP

Bill number 227962

Page 8

Lakeside Plantation Community Development District
Re: Dispute with Former Employee - Carrie Greus

I.D. L00243-137443 JAC

TOTAL FEES	8,367.00
TOTAL DISBURSEMENTS	38.00
TOTAL CHARGES FOR THIS BILL	8,405.00
TOTAL DUE FOR THIS BILL	8,405.00
BALANCE FORWARD	8,819.50
TOTAL DUE FOR THIS MATTER	\$ 17,224.50

SHUMAKER, LOOP & KENDRICK, LLP
240 SOUTH PINEAPPLE AVENUE
P.O. BOX 49948
SARASOTA, FLORIDA 34230-6948

(941) 366-6660

FEDERAL TAX NO. 34-4439491

June 9, 2010

Billed through 05-31-10

Bill number 229930

Lakeside Plantation Community Development District
Attn: Chairman
2200 Plantation Blvd.
North Port, FL 34289

I.D. L00243-137443 JAC

RE: Dispute with Former Employee - Carrie Greus

Previous Balance		17,224.50
Net Payments		<5,967.00>
Balance Forward		11,257.50
Current Fees	3,627.00	
Current Disbursements	2.80	
Total Due for this Bill		3,629.80
Total Due for this Matter		\$ 14,887.30

**** PLEASE REMIT THIS PAGE WITH YOUR PAYMENT ****

PAYMENT DUE WITHIN 30 DAYS.

Invoices remaining unpaid 30 days after date of invoice will be
charged a late payment charge of 1.5% per month.

SHUMAKER, LOOP & KENDRICK, LLP

Bill number 229930

Page 2

Lakeside Plantation Community Development District
 Re: Dispute with Former Employee - Carrie Greus

I.D. L00243-137443 JAC

FOR PROFESSIONAL SERVICES RENDERED

DATE	ATTY	DESCRIPTION OF SERVICES	HOURS	RATE/HR	AMOUNT
05-03-10	JAC	Review e-mail from C. Sensenig regarding C. Greus unemployment compensation benefits; review Separation Agreement regarding unemployment compensation issue; prepare e-mail to B. Lamb regarding C. Greus unemployment compensation benefits.	0.20	250.00	50.00
05-04-10	JAC	Review e-mails from C. Sensenig regarding status of settlement documents; prepare e-mail to C. Sensenig regarding status of settlement documents; e-mails to and from B. Lamb regarding status; office conference with W. Cox regarding status.	0.40	250.00	100.00
05-05-10	JAC	E-mails to and from B. Lamb regarding reference issue, unemployment compensation issue, and finalizing settlement documents; e-mails to and from C. Sensenig regarding reference issue, unemployment compensation issue, and finalizing settlement documents; prepare final revisions to Settlement Agreement.	0.50	250.00	125.00
05-07-10	JAC	Receipt and review correspondence from C. Sensenig regarding Settlement Agreement; review Settlement Agreement regarding payment deadlines; office conference with W. Cox regarding issues with finalizing settlement agreement; prepare e-mail to B. Lamb regarding finalizing settlement agreement and deadlines.	0.60	250.00	150.00
05-10-10	WPC	Office conference with J. Collier regarding finalizing C. Greus settlement agreement.	0.30	175.00	52.50

SHUMAKER, LOOP & KENDRICK, LLP

Bill number 229930

Page 3

Lakeside Plantation Community Development District
 Re: Dispute with Former Employee - Carrie Greus

I.D. L00243-137443 JAC

FOR PROFESSIONAL SERVICES RENDERED

DATE	ATTY DESCRIPTION OF SERVICES	HOURS	RATE/HR	AMOUNT
05-10-10	JAC Numerous e-mails from D. Sullivan regarding checks, payment of settlement funds, and settlement agreement issues; numerous e-mails to D. Sullivan regarding checks, payment of settlement funds, and settlement agreement issues; e-mails to and from C. Sensenig regarding settlement documents and gross vs. net issue; telephone conversation with C. Sensenig regarding finalizing settlement documents and gross vs. net payment issue; receipt of correspondence from C. Sensenig regarding settlement documents; prepare additional revisions to Settlement Agreement regarding tax indemnity language and gross vs. net payment issue; office conference with W. Cox regarding finalizing settlement documents and strategy discussions.	1.50	250.00	375.00
05-11-10	JAC Review correspondence from C. Sensenig regarding Settlement Agreement; review Settlement Agreement executed by C. Greus; prepare e-mail to B. Lamb regarding Settlement Agreement.	0.30	250.00	75.00
05-13-10	WPC Office conferences with J. Collier regarding finalizing settlement agreement; review final agreement signed by C. Greus.	0.40	175.00	70.00
05-13-10	JAC Receipt and review letters from C. Sensenig regarding Greus matter, settlement agreement and W-9; review revised executed Settlement Agreement regarding payment deadlines; review W-9 from C. Sensenig; office conference with			

SHUMAKER, LOOP & KENDRICK, LLP

Bill number 229930

Page 4

Lakeside Plantation Community Development District
 Re: Dispute with Former Employee - Carrie Greus

I.D. L00243-137443 JAC

FOR PROFESSIONAL SERVICES RENDERED

DATE	ATTY	DESCRIPTION OF SERVICES	HOURS	RATE/HR	AMOUNT
		W.Cox regarding status, payment deadlines, and notification to Board of obligations under Agreement; prepare e-mail to B. Lamb regarding status and notification to Board; telephone conversation with B. Lamb regarding status, strategy discussions, and notification to Board of obligations under Agreement; review Agreement regarding obligations on Board once Agreement is executed with respect to "neutral reference" language; draft e-mail to Board regarding obligations under Agreement.	2.10	250.00	525.00
05-14-10	JBC	Office conference with J. Collier.	0.20	310.00	62.00
05-14-10	JAC	Review e-mail from C. Sensenig regarding Settlement Agreement and status; prepare e-mail to C. Sensenig regarding Settlement Agreement and status; office conference with W. Cox regarding settlement agreement, payment deadlines, and status.	0.30	250.00	75.00
05-18-10	WPC	Review follow-up e-mail from C. Sensenig regarding finalizing settlement agreement; e-mail to B. Lamb regarding the same; telephone conference with V. Weinkauff regarding B. Capozzi's objections to the settlement agreement.	0.60	175.00	105.00
05-18-10	JBC	Telephone conference with V. Weincoff regarding concerns with settlement agreement.	0.30	310.00	93.00
05-19-10	WPC	Review e-mails from B. Lamb and V. Weinkauff regarding finalizing Greus settlement.	0.30	175.00	52.50

SHUMAKER, LOOP & KENDRICK, LLP

Bill number 229930

Page 5

Lakeside Plantation Community Development District
 Re: Dispute with Former Employee - Carrie Greus

I.D. L00243-137443 JAC

FOR PROFESSIONAL SERVICES RENDERED

DATE	ATTY	DESCRIPTION OF SERVICES	HOURS	RATE/HR	AMOUNT
05-19-10	WPC	Review and respond to e-mail from V. Weinkauff regarding legal issue of settlement agreement binding future Boards as requested by CDD Board Chair and Vice Chair; office conference with J. Compton regarding the same.	0.80	175.00	140.00
05-19-10	JBC	Answer e-mail questions; e-mail to opposing counsel.	0.30	310.00	93.00
05-19-10	JBC	Receipt and review e-mail from District Management regarding questions; office conference with W. Cox regarding response.	0.20	310.00	62.00
05-20-10	WPC	E-mails to and from B. Lamb, V. Weinkauff, and J. Compton, regarding finalizing Greus settlement; office conference with J. Compton regarding the same.	0.80	175.00	140.00
05-20-10	JBC	E-mail from and to opposing counsel; e-mail to and from client; office conference with W. Cox; e-mail to client.	0.40	310.00	124.00
05-20-10	JBC	E-mail from client; telephone conference with opposing counsel; draft and dictate amendment; e-mails to and from client; e-mails with opposing counsel.	0.60	310.00	186.00
05-21-10	WPC	Revise and finalize e-mail to CDD Board of Supervisors regarding compliance with Greus settlement agreement.	1.00	175.00	175.00
05-21-10	WPC	Review CDD Board Agenda for upcoming meeting.	0.50	175.00	87.50
05-23-10	JAC	Review e-mails from C. Sensenig regarding Greus settlement			

SHUMAKER, LOOP & KENDRICK, LLP

Bill number 229930

Page 6

Lakeside Plantation Community Development District
 Re: Dispute with Former Employee - Carrie Greus

I.D. L00243-137443 JAC

FOR PROFESSIONAL SERVICES RENDERED

DATE	ATTY DESCRIPTION OF SERVICES	HOURS	RATE/HR	AMOUNT
	documents; review e-mail from B. Lamb regarding Greus settlement documents; review e-mails from V. Weinkauf regarding Greus settlement documents; review Amendment to Settlement Agreement; review statute regarding "settlement documents" as public record; review and revise notification language to Board regarding obligations under Agreement.	0.40	250.00	100.00
05-24-10	WPC Office conference with J. Collier regarding final Greus settlement agreement and related e-mail to CDD Board; e-mail to and from V. Weinkauf regarding the same.	0.70	175.00	122.50
05-24-10	JAC Prepare notification to Board of execution of Agreement with Carrie Greus and obligations thereunder; office conference with W. Cox regarding Settlement Agreement and e-mail notification to Board members; review versions of Settlement Agreement and Amendment to Settlement Agreement regarding final settlement documents and outstanding signature; e-mails to and from B. Lamb and V. Weinkauf regarding need for Mr. Capozzi to execute final version of Settlement Agreement; prepare e-mail to C. Sensenig regarding final settlement documents.	1.60	250.00	400.00
05-24-10	JBC Work with J. Collier on execution of Settlement Agreement - corrected.	0.20	310.00	62.00
05-25-10	JAC Review e-mail from C. Sensenig regarding final settlement documents.	0.10	250.00	25.00

SHUMAKER, LOOP & KENDRICK, LLP

Bill number 229930

Page 7

Lakeside Plantation Community Development District
Re: Dispute with Former Employee - Carrie Greus

I.D. L00243-137443 JAC

FOR PROFESSIONAL SERVICES RENDERED

DATE	ATTY DESCRIPTION OF SERVICES	HOURS	RATE/HR	AMOUNT
	Total Fees for this Matter	15.60 hrs	\$	3,627.00
DISBURSEMENTS				
	Document Reproduction			2.80
	Total Disbursements for this Matter		\$	2.80
BILLING SUMMARY				
	Jennifer B. Compton	JBC	2.20 hrs \$ 310.00 /hr	682.00
	Jason A. Collier	JAC	8.00 hrs \$ 250.00 /hr	2,000.00
	William P. Cox	WPC	5.40 hrs \$ 175.00 /hr	945.00
	TOTAL FEES			3,627.00
	TOTAL DISBURSEMENTS			2.80
	TOTAL CHARGES FOR THIS BILL			3,629.80
	TOTAL DUE FOR THIS BILL			3,629.80
	BALANCE FORWARD			11,257.50
	TOTAL DUE FOR THIS MATTER		\$	14,887.30

WELCOME TO PRO AUDIO SERVICES, INC.

PRO AUDIO SERVICES, INC. is a full-service, audio/video company that provides sound reinforcement, distributed sound and video systems for a variety of commercial, governmental, religious and residential applications. We design, install, user train and maintain our systems, as well as non-PAS supplied equipments.

We are headquartered in North Port, FL. and generally operate between Naples and the Tampa metropolitan area. We man a 24 hour / 7 day service network in the unlikely event of a major system outage.

PRO AUDIO SERVICES, INC is particularly proud of an unblemished record of satisfactory system installations, exemplified by a large customer reference list. This is accomplished by:

- thoughtful design
- superior equipments
- quality installation, testing and training
- punctual project management
- ability to provide audio, video and other low voltage systems
- fair pricing

We encourage prospective customers to consider and verify our unequaled references. We will be pleased to provide you contact information on any reference.

WARRANTY

PRO AUDIO SERVICES WARRANTS ITS SERVICES TO BE FREE OF DEFECTS IN WORKMANSHIP FOR A PERIOD OF ONE (1) YEAR FROM THE DATE OF INSTALLATION. DURING THIS WARRANTY PERIOD, PRO AUDIO SERVICES WILL CORRECT ANY DEFECTS IN ITS WORKMANSHIP AT NO COST TO THE OWNER.

ADDITIONALLY, PRO AUDIO SERVICES PASSES ON TO THE OWNER, INDIVIDUAL EQUIPMENT WARRANTIES FROM THE RESPECTIVE MANUFACTURERS FOR EACH PIECE OF EQUIPMENT SUPPLIED. THE WARRANTY PERIODS MAY RANGE UP TO SIX (6) YEARS, DEPENDING ON THE TYPE/MANUFACTURER OF THE EQUIPMENT. THIS IS A FACTORY REPAIR WARRANTY AND MAY REQUIRE THE RETURN OF THE DEFECTIVE EQUIPMENT TO A REPAIR DEPOT.

SERVICE LABOR, SHIPPING CHARGES AND "LOANER" EQUIPMENT RELATING TO DEFECTIVE EQUIPMENT IS NOT COVERED BY MANUFACTURER WARRANTY AND MAY BE BILLABLE TO THE CLIENT.

CHURCHES

Apostolic Church - North Port At the Church of the Living Christ Edgewater Church of God Indies Evangelical Church Bethany Temple Church of God Bethel Community Baptist Bethel Lutheran Bower Chapel Buckingham Presbyterian Calvary Bible Church Cape Coral United Methodist Capri Christian Cardinal Mooney Chapel Center for Faith & Freedom Chapel on the Hill Church of the Nativity Church of the Nazarene - Arcadia Colonial Baptist Church Community of Christ Cornerstone Presbyterian Covenant Presbyterian Crossroads Baptist Church Crossroads Community Church Daniels Road Baptist Church Edgewater United Methodist Emmanuel Lutheran Emmanuel United Methodist Epiphany Cathedral Hero United Methodist Angel Baptist Church Faith Baptist Church Faith Lutheran Lecanto Fellowship of Believers First Baptist Church – Arcadia First Baptist Church – Inverness First Baptist Church – Osprey First Baptist Church – Pine Island First Christian Church – Venice First Church of the Nazarene First Congregational Church - SRQ First Congregational Church - SRQ	First Missionary Baptist - Okeechobee First Presbyterian Bartow First Presbyterian Sarasota First United Methodist - Dunellon First United Methodist Naples FishHawk Fellowship Fort Myers Christian Church Grace Lutheran Grace Presbyterian Grace United Methodist Grand Island Baptist Guadeloupe Center Gulf Coast Church of Christ Gulf Cove United Methodist Hillsborough United Methodist Holy Trinity Lutheran – Pt. Charlotte Hopewell Baptist Church Independent Pentecostal Iona Hope Episcopal Church Island Community Church Koinonia Missionary Baptist Lake Placid Church of Christ Lamb of God Lutheran Lighthouse Baptist Church - Ft. Myers Marco Church of God Marco Lutheran Church Marco Presbyterian Mayflower UCC Moorings Presbyterian Morningstar Baptist Church Mt. Olive Missionary Baptist Naples Christian Church Naples Church of Christ Northside Christian NW Tampa Church of God Oakview Baptist Orange Avenue Church of Christ Our Lady of Angels Our Lady of Mercy Our Lady of Mount Carmel Our Lady of Perpetual Help	Our Savior Lutheran Palm Lane Baptist Peace Lutheran Church Placid Temple Church of God Plant City Church of God Punta Gorda Congregational UCC Redeemer Lutheran - Ft. Myers Richmond Avenue Baptist Church Riverview United Methodist Sacred Heart Salvation Army Worship Center San Marco Catholic Church Silver Lake Community Church Simmons Loop Baptist South Venice Baptist Southside Church of Christ Springhill United Church of Christ St. Agnes Catholic St. Andrews Ukrainian St. Charles Borromeo St. Finnbar St. Francis of Assisi St. Hilary's Episcopal Church St. James United Methodist St. John the Evangelist St. Jude Social Center St. Mary Magdalene Episcopal St. Monica Episcopal Church St. Paul Lutheran St. Raphael Catholic Church St. Thomas More Catholic Church The Bridge Church The Monks of Adoration The Sanctuary - Deland Trinity Presbyterian Church - Venice True Vine Missionary Baptist Union Street United Methodist Victory Baptist Victory Church West Charlotte Baptist
---	---	---

SCHOOLS/MUNICIPALITIES

Alta Vista Elementary Avalon Elementary Baron Collier High School Big Cypress Elementary Bishop Nevins Academy Cardinal Mooney High School Charlotte County Health Center City of Bradenton Beach City of Ft. Myers Imaginarium City of Lake Wales City of Punta Gorda Corkscrew Middle School Cypress Palm Middle School East Naples Middle School Englewood Elementary	Florida Gulf Coast University Fort Myers High School Golden Gate High School Gulf Coast High School Immokalee High School Lake Park Elementary Laurel Nokomis School* Lehigh Senior High School Lely Elementary Lely High School Mt. Dora Christian Home & Bible School Myakka River Elementary Naples High School Naples Park Elementary North Naples Middle School	Oakridge Middle School Palmetto ridge High School Poinciana Elementary Port Charlotte High School Riverview High School Sarasota Military Academy Shadowlawn Elementary St. Martha's School Toledo Blade Elementary USCG Hangar St. Petersburg Venice High School Venice Library Venice Skate Park Vineland Elementary
--	--	---

CLUBHOUSE/AMENITIES

Aversana	Islandwalk Town Center	Riverwalk Clubhouse
Bay Plaza	Islandwalk Town Center	Royal Wood G & CC
Bella Sera Resort	Isles Yacht Club	Serano
Bay Terra Clubhouse	Jacaranda Country Club	Spanish Lakes
Castillo	Japanese Gardens	Spanish Wells
Collier Reserve	King's Gate	St. Maarten
Colony Bay Club	La Playa	Stoneybrook G & CC
Cove Towers Calypso Club	La Scala @ The Colony	Sun City Welcome Center
Crown Colony G & CC	Lazy River MHP	Sun N Fun RV Park
Cypress Woods RV Park	Lettuce Lake RV Park	Tangerine Woods
Deep Creek Gardens	Longshore Lake	The Colony G & CC
Emerald Lakes	Navona	The Estuary at Grey Oaks
Foxfire G & CC	Olde Cypress G & CC	The Preserve at Tara
Foxwood	Osprey Cove Clubhouse	Tiburon G & CC
Grande Isles 1 & 2	Palmira G & CC	Tuscany Cove
Grandezza G & CC	Park Hill, Inc.	Tuscany Golf Studio
Greenfield Commons	Pelican Landing	Venetia Clubhouse
Gulf Harbour Country Club	Pelican Preserve	Venetian Golf Club
Gulf To Bay Co-Op	Pelican Sound G & CC	Venetian Park
Hammock Bay	Pelican's Nest G & CC	Waterchase
Hampton Park	Pinebrook-Ironwood	Waterlefe G & CC
Heritage Point	Plantation Estates	Westshore Yacht Club
Heron Creek G & CC	Platinum Point Yacht Club	Wildcat Run
High Point G & CC	Quail West	Windmill Village
Imperial Golf Club	River Wilderness G & CC	Windstar G & CC

FITNESS/WELLNESS CENTERS

Bally Total Fitness Pinellas	LFF East Bay	LFF Tyrone
Bally Total Fitness Tampa	LFF Hunter Creek	LFF Venice
Bally Total Fitness Clearwater	LFF Hyde Park	LFF Westchase
Bally Total Fitness Orlando	LFF Lake Mary	LFF Wintergarden
Lee Center for Rehabilitation and Wellness	LFF North Lakeland	LFF Winterhaven
LFF Alamo	LFF Ohio Columbus	LFF Winterpark
LFF Altamonte Springs	LFF Ohio Gahanna	Colony Fitness Center
LFF Apex Crossing	LFF Ohio Henderson	Cape Coral Wellness Center
LFF Apopka	LFF Ohio Hillard	NCH Wellness – Briggs
LFF Atlantic	LFF Ohio NEC	NCH Wellness – Greentree
LFF Beneva	LFF Ohio New Albany	Palmira Renaissance Fitness
LFF Bloomingdale	LFF Ohio Polaris	Paramount Fitness Center
LFF Bradenton	LFF Ohio Sawmill	Punta Gorda Fitness Club
LFF Brandon	LFF Orange Park	Stoneybrook Fitness Center
LFF Carrollwood	LFF Sarasota	The Studio Venice
LFF Cortez	LFF Seminole	Tiburon Fitness Center
LFF Countryside	LFF St. Pete	Twist for Women
LFF Creekwood	LFF Tampa Palms	Gateway Fitness

RESTAURANTS

Bootleggers	Crow's Nest	Ruby Tuesday's Ellenton
Breaker's Restaurant	Dolce Vita Restaurant	Ruby Tuesday's Port Richie
Buca di Beppo Davie	Jam's of Cape Haze	Sharky's
Buca di Beppo Ft. Lauderdale	Jam's on Boca Grande	South Beach Bar & Grille
Buca di Beppo Maitland	Joe Cracker	The Florida Club
Buca di Beppo Naples	Lock & Key	The Samba Room
Buca di Beppo Tampa	Rice Republic Restaurant	The Tasting Room
Crazy Buffet Altamonte Springs	Roaring 20's Restaurant	The Turtle Club Punta Gorda
Crazy Buffet Tampa		Tulie's

OTHER COMMERCIAL

Ajax Paving Industries
American Legion # 159
Art League of Bonita Springs
Arthritis Foundation
Association of Realtor's
Ave Maria Development
Bank of America Investment Services
Bartow Ford
Bay Indies Hall
Bay Plaza
Bella Sera Hotel
Benderson Development
Boca Bande
Boca Grande Community Center
Boca Grande Historical Society
BPOE # 2153
Brandon Dodge
Buelow Financial Center
Busey Bank Punta Gorda
Carlisle ACLF - Naples
Carlisle ACLF - Palm Beach
Cypress Lakes Center for the Arts
Diamond Head Resort
Florida Community Bank
Florida Eye Health

Fort Myers Toyota New Car Sales
Fort Myers Toyota Reconditioning Ctr
Fort Myers Toyota Truck Sales
Fort Myers Toyota Used Car Sales
Fox Lea Farms
Gull Wing Resort
Happy Feet DJ Service
Hampton Inn Ellenton
Harbor Imaging
Harbor Nissan
HMS Host @ SWFIA
Holiday Inn Lakewood Ranch
Hope Hospice - CC, FM, BS
Hope Hospice Adult Day Care
Islandwalk Town Center
Lemon Bay Garden Club
Maajoun North Port BP
Meals on Wheels Plus
Moose Lodge Bradenton
Murdock Ambulatory Service Center
Murdock Carousel Shopping Center
Nielsen Media Research
North Port Diagnostic Imaging
North Port Little League
Okeechobee Community Theater
Olde Florida Bank

Oyster Creek Golf Pro Shop
Palm Harbor Honda
Panther Hollow Dental Lodge
Pelican Preserve Public Safety Unit
Plantation Management Assoc
Platinum Point Yacht Club
Polynesian Villagers, Inc
Quality Precast
Radisson Lido Beach resort
Raymond James
Royal Palm Bank
San Carlos Little League
Sleep Inn Orlando
Smith Barney
Store-N-More
Sun City Welcome Center - Tampa
Sun N Fun
SW Fla Regional Planning Council
Tarpon Coast Bank - Englewood
Tarpon Coast Bank - Murdock
Treasure Lanes/City Limits
Venice Community Center
VFW Post 2824
Waterside Sales Office
Wooten's Tour Train

Pro Audio Services

3195-A Commerce Parkway
North Port, FL 34289

Project Number 8138

8/22/2010 Page: 1 **** Estimate ****
941-876-3386 Fx 941-876-3368

Lakeside Plantation
Bill Capozzi
2200 Plantation Blvd
North Port, FL 34289

C12087 941/423-5500 Fax: 941/423-5501

Project Title..: Wireless Mic System

System provides a mobile rack on wheels to house (5) wireless lapel mics and a simple mixer to allow audio mixing. There will be a custom plate to allow interfacing between the "house" sound system and an owner furnished handheld microphone. A rack mounted power distribution unit and storage drawer are included to simplify set-up, tear-down and storage of equipment and accessories. Options TBD include a Compact Flash card recorder and an audio distribution unit to allow interfacing to the recorder and an owner furnished computer for streaming of meetings.

Wireless Microphones

- 5 Audio-Technica-ATW-2110, ATW-R2100 Rcvr & ATW-T210 UniPak® Xmtr (TV 45-48) transmitter (TV 45-48)
- 5 Audio-Technica-MT830CW, MT830c Miniature Omnidirectional Condenser Lavalier Mic w/55" Cable Term w/Locking 4-pin HRS Conn. Wireless Essentials#
- 5 Rapco-AJ-6, 6 FT 24 GA MIC CABLE W/ ALCATEL CONNECTORS

Mixer and external interfacing

- 1 Shure-SCM800, Eight-Ch Mic Mixer w/ EQ per Ch, AC only, One Rack Space
- 1 Rapco-CUSTOM, Custom Fill Rack Plate, Engraved
- 2 Rapco-AJ-25, 25 FT 24 GA MIC CABLE W/ ALCATEL CONNECTORS

Equipment Rack, Power Conditioner, Set-up and Training

- 1 Grundorf-ER-16RB, EQUIP RACK - 16 SPACE, 16.5" BODY RECESSED, BLACK
- 1 Grundorf-CSMC2B, medium caster (3" wheel) dolly plate with 2 breaks for combo single
- 1 Grundorf-75-103, RACK DRAWER - 3 SPACE 13.75" DEEP, KEY LOCK, BLACK
- 4 Lowell-LE-191, Blank pnl economy 1PS 1RU 18ga CRS flange
- 1 Juice Goose-JG8.0, 8 outlets. Base level power protection.
- 1 MBT-0261, 15' Extension Cord

Labor

All parts installed in rack. All wireless units programmed for optimum operation and labeled. Rack delivered and set-up on site. Integrated with existing sound system and tested. Operations personnel trained in use of system.

Subtotal

3,955.78

Pro Audio Services

3195-A Commerce Parkway
North Port, FL 34289

Project Number 8138

8/22/2010 Page: 2 * * Estimate * *
941-876-3386 Fx 941-876-3368

Options

Option 1 - Audio Distribution unit

This is needed to allow the next 2 options

- 1 RDL-STM-DA3, Mic Level Distribution Amplifier - 1x3
- 1 RDL-PS-24A, 24Vdc 400mA Pwr Supply - Leads
- 1 PAS-MISC MATERIALS, Misc Materials
- Labor to Install

Subtotal

=====
287.25

Option 2 - Audio Recording Device

Provides the ability to record audio from the audio mixing board

- 1 D-M Pro-PMD560, Rack mount Solid State CF recorder, RS232
- 1 Lexar Platinum II 4Gb Compact Flash Card
- 1 Sandisk ImageMate 12x1 Memory Card Reader
- 1 PAS-MISC MATERIALS, Misc Materials, connectors, cables etc.
- Labor

Subtotal for Add Alternate 1 - Audio Recording Device

=====
709.70

Option 3 - Add feed for Computer Streaming

- 1 Rapco-CUSTOM, Add XLR-F jack to custom rack plate
- 1 Rapco-AJ-25, 25 FT 24 GA MIC CABLE W/ ALCATEL CONNECTORS

Subtotal

=====
26.79

Total if all options selected

=====
4,979.52

This * * Estimate * * is Valid for 60 Days.

Bertler, Christopher T

I Accept This Quote _____ Date: _____

FREQUENCY-AGILE TRUE DIVERSITY UHF WIRELESS SYSTEMS

ATW-2110 UniPak™ Transmitter System
ATW-2120 Handheld Dynamic Microphone System

2000 SERIES



ATW-R2100

Automatic Frequency Scanning

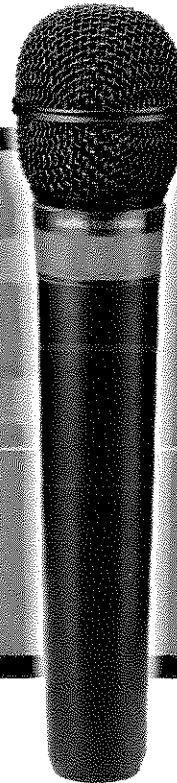

ATW-T220

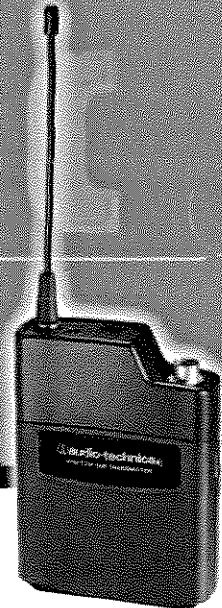

ATW-T210

SERIOUS ADVANCES IN AFFORDABLE WIRELESS

Audio-Technica's innovative 2000 Series wireless delivers professional performance unheard of in its class. With this breakthrough series, Audio-Technica makes easy setup, automatic scanning and other advanced wireless features affordable as never before.

Automatic frequency scanning—standard on all 2000 Series wireless receivers—finds and sets the best available channel at the touch of a button. For those using multiple wireless systems simultaneously, the 2000 Series offers another ease-of-use standout: any of its 10 channels may be used together—eliminating confusing frequency groups and other frequency-coordination problems.

SYSTEM FEATURES

- Clear sound quality and rock-solid, dependable performance
- Automatic frequency scanning finds an open channel at the touch of a button
- All 10 user-switchable channels are compatible—for easy use with multiple systems; no confusing frequency groups
- True Diversity operation selects the better signal from the two receiver sections, reducing dropouts
- Tone Lock™ tone squelch system fights interference
- Rugged metal half-rack receiver with soft-touch controls and LCD display featuring RF and AF metering
- Balanced XLR and unbalanced 1/4" output jacks enable use with a wide variety of audio gear
- Includes rack-mount kit and detachable UHF antennas
- Ground-lift switch helps eliminate audible hum caused by ground loops between the sound system and receiver
- ATW-T220 Handheld Microphone/Transmitter features PRO 41 capsule for maximum feedback rejection and consistent sound

 **audio-technica.**
always listening.™

2000 SERIES

Specifications†

Overall System

Operating Frequency	UHF band, 656.125 to 678.500 MHz
Number of Channels	10 total
Frequency Stability	±0.005%, Phase Lock Loop frequency control
Modulation Mode	FM
Normal Deviation	±5 kHz
Operating Range	300' typical
Operating Temperature Range	41° F (5° C) to 113° F (45° C)
Frequency Response	100 Hz to 15 kHz

ATW-R2100 Receiver

Receiving System	Dual independent receivers, automatic-switching diversity
Image Rejection	55 dB nominal, 50 dB minimum
Signal-to-noise Ratio	>100 dB at 40 kHz deviation (A-weighted), maximum modulation 40 kHz
Total Harmonic Distortion	<1% (±10 kHz deviation at 1 kHz)
Sensitivity	20 dBµV [S/N 60 dB at 5 kHz deviation, IEC-weighted]
Intermediate Frequency	65.75 MHz, 10.7 MHz
Audio Output (AF Level set at "0")	
Unbalanced:	25 mV [at 1kHz, ±5 kHz deviation, 100k ohm load]
Balanced:	12.5 mV [at 1kHz, ±5 kHz deviation, 100k ohm load]
Output Connectors	
Unbalanced:	1/4" phone jack
Balanced:	XLRF-type
Power Supply	120V AC 60 Hz, or 12-18V DC, 350 mA, with external supply
Dimensions	8.27" [210.0 mm] W x 1.73" [44.0 mm] H x 6.39" [162.2 mm] D
Weight	2.2 lbs [1.0 kg]
Accessories Included	Two flexible UHF antennas, rack-mount adapters, AC adapter

Wireless Essentials™ Microphones and Cables

All Wireless Essentials accessories are terminated for use with all A-T UniPak™ transmitters.

AT829cW	Miniature cardioid condenser lavalier microphone.
MT830cW	Miniature omnidirectional condenser lavalier microphone.
MT830cW-TH	"Theater" model, same as MT830cW except beige color mic and cable.
AT831cW	Miniature cardioid condenser lavalier microphone.
AT889cW	Headworn noise-canceling condenser microphone.
AT892cW	MicroSet® headworn omnidirectional condenser microphone.
AT892cW-CD	Same as AT892cW except cocoa color mic, earset and cable.
AT892cW-TH	"Theater" model, same as AT892cW except beige color mic, earset and cable.
AT898cW	Subminiature cardioid condenser lavalier microphone.

ATW-T210 UniPak™ Transmitter

RF Power Output	12 mW
Spurious Emissions	Under federal regulations
Input Connections	High impedance, low impedance, bias
Batteries [not included]	Two 1.5V AA alkaline
Current Consumption	150 mA typical
Battery Life	Approximately 9 hours (depending on battery type and use pattern)
Dimensions	2.60" [66.0 mm] W x 3.63" [92.3 mm] H x 0.89" [22.5 mm] D
Net Weight (without batteries)	2.82 oz (80 g)

ATW-T220 Handheld Transmitter

RF Power Output	12 mW
Spurious Emissions	Under federal regulations
Microphone Element	Dynamic, unidirectional
Batteries [not included]	Two 1.5V AA alkaline
Current Consumption	150 mA typical
Battery Life	Approximately 9 hours (depending on battery type and use pattern)
Dimensions	9.02" [229.0 mm] long, 2.11" [53.5 mm] max. dia.
Net Weight (without batteries)	7.81 oz [221.5 g]
Accessory included	AT8456a Quiet-Flex™ stand clamp

† In the interest of standards development, A.T.U.S. offers full details on its test methods to other industry professionals on request.

Specifications are subject to change without notice.

AT899cW	Subminiature omnidirectional condenser lavalier microphone.
AT899cW-TH	"Theater" model, same as AT899cW except beige color mic and cable.
ATM35cW	Cardioid condenser instrument microphone.
ATM73cW	Headworn cardioid condenser microphone.
ATM75cW	Headworn cardioid condenser microphone.
PRO 8HEcW	Headworn hypercardioid dynamic microphone.
PRO 35xcW	Cardioid condenser instrument microphone.
U851cW	Cardioid condenser boundary microphone.
U857ALcW	Cardioid condenser gooseneck microphone. Mounts to 1/8"-27 thread.
AT-GCW	Hi-Z instrument/guitar cable with 1/4" phone plug.
XLRW	Connecting cable for UniPak transmitter with an XLRF-type input connector, for Lo-Z microphones with XLRM-type output terminations.

 **audio-technica.**
always listening™

Audio-Technica U.S., Inc. 1221 Commerce Drive, Stow, Ohio 44224
(330) 686-2800 Fax: (330) 686-0719 E-mail: pro@atus.com www.audio-technica.com

Visit our Web site @ www.audio-technica.com for extensive information on selecting and using wireless systems.

Form No. 0466-2400-01 ©2006 Audio-Technica U.S., Inc. Printed in U.S.A.



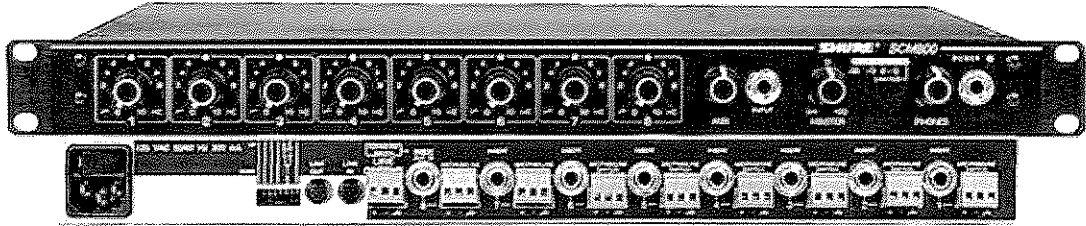

Shure SCM800



SCM800/SCM800E Microphone Mixers Specification Sheet

SCM800/SCM800E EIGHT-CHANNEL MICROPHONE MIXER

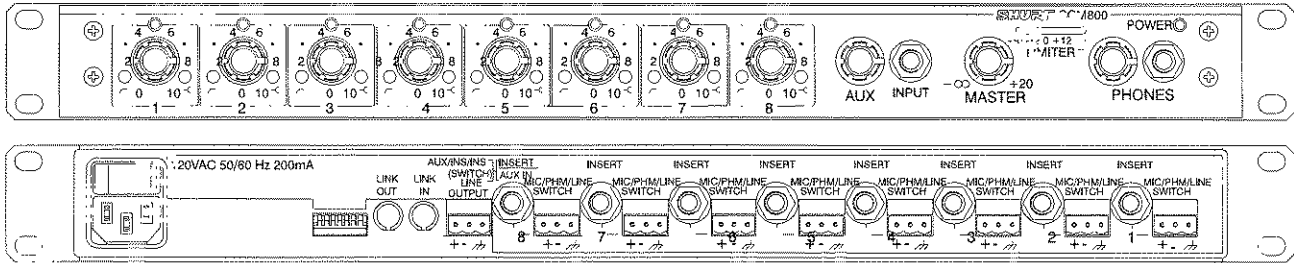

SYSTEM FEATURES

The Shure Model SCM800 is a full-featured, eight-channel microphone mixer for sound reinforcement, general audio recording, and audio-visual systems. Any low-impedance, balanced dynamic or condenser microphone, including a wireless microphone system, can be used with the SCM800 mixer.

Each SCM800 accepts up to eight microphone- or line-level inputs and one aux-level input (two input jacks feed the same channel). Up to four SCM800 mixers can be linked to provide up to 32 input channels. Each input channel has a two-band equalizer, switchable mi-

crophone- or line-level operation, switchable 48 V phantom power, and a 1/4-inch send/receive insert jack.

The SCM800 operates on 120 Vac power; the SCM800E operates 230 Vac power. Both models are supplied with rack-mounting hardware, link cable and removable block terminal connectors. An accessory rack panel adapter (Model RKC800, available separately) converts the removable block input and output connectors to XLR connectors, and the Aux connectors to phono jacks.

FEATURES

- Compatible with Shure SCM810 and FP410 automatic microphone mixers
- Adjustable EQ per channel: low-frequency rolloff and high-frequency shelving
- 48 V phantom power selectable for each input
- Active balanced microphone- and line-level inputs and line-level output
- Highly RF-resistant chassis and circuitry
- LED indication of channel clipping
- Linking capability for systems up to 32 microphones
- Two Aux-level input jacks that feed one channel
- Insert jack on each channel
- Manual mixing of input channels
- Internal Modification permits 230 V operation (SCM800) or 120 V operation (SCM800E)
- Front-panel headphones output with level control
- Peak-responding output limiter with selectable thresholds and LED indicator

SPECIFICATIONS

Measurement Conditions (unless otherwise specified):

Line voltage 120 Vac, 60 Hz (SCM800) or 230 Vac, 50 Hz (SCM800E); full gain; 1 kHz.

Source impedances: Mic 150 Ω, Line 150 Ω.

Terminations: Line 10 kΩ, Phones 300 Ω (tip-sleeve and ring-sleeve), Direct Out 10 kΩ.

Equalization controls adjusted for flat response, Channel 1 gain control full clockwise, other gain controls full counterclockwise

Frequency Response (Ref .1 kHz, channel controls centered)
50 Hz to 20 kHz ±2 dB; -3 dB corner at 25 Hz

Voltage Gain (typical, controls full clockwise)

Input	Output		
	Line	Head-phones	Direct Out
Low-impedance mic (150 Ω)	80 dB	88 dB	34 dB
Line	40 dB	48 dB	-6 dB
Aux	44 dB	52 dB	—
Send/Return	20 dB	28 dB	—

Inputs

Input	Impedance		Input Clipping Level
	Designed for use with	Actual (typical)	
Mic	19-600 Ω	10 kΩ	-15 dBV
Line	≤2 kΩ	10 kΩ	+22 dBV
Aux	≤2 kΩ	10 kΩ	+22 dBV
Send/Return	≤2 kΩ	10 kΩ	+18 dBV

Outputs

Output	Impedance		Output Clipping Level
	Designed for use with	Actual (typical)	
Line	>600 Ω	60 Ω	+18 dBV
Headphones	8-200 Ω, 60 Ω recommended	300 Ω	+12 dBV
Direct Out	>2 kΩ	1 kΩ	+18 dBV
Send/Return	>2 kΩ	1 kΩ	+18 dBV

Total Harmonic Distortion

<0.1% at +18 dBV output level, 50 Hz to 20 kHz (through 20 Hz-20 kHz filter; Input 1 and Master at 5, all other controls full counterclockwise)

Hum and Noise

Equivalent Input Noise: -125 dBV (150 Ω source; through 400 Hz-20 kHz filter)

Equivalent Input Hum and Noise: -123 dBV (150 Ω source; through 20 Hz - 20 kHz filter)

Output Hum and Noise (through 20 Hz to 20 kHz filter; channel controls full counterclockwise):

Master full counterclockwise: -90 dBV

Master full clockwise: -62 dBV

Common Mode Rejection

>70 dB at 1 kHz

Polarity

Mic/Line, Send inputs to all outputs are non-inverting; Aux input to all outputs is inverting

Overload and Shorting Protection

Shorting outputs, even for prolonged periods, causes no damage. Microphone inputs are not damaged by signals up to 3 V; Line and Monitor inputs by signals up to 20 V

Equalization

Low-frequency: 6 dB/octave cut, adjustable . corner from 25 to 320 Hz

High-frequency: ±6 dB at 5 kHz, ±8 dB at 10 kHz, shelving

Limiter

Type: Peak

Threshold: Switchable: off, +4, +8, +16 (dBm at output)

Attack Time: 2 ms

Recovery Time: 300 ms

Indicator: Lights red when limiting occurs

Input LEDs

Light at 6 dB below clipping

Phantom Power

46 Vdc open-circuit through 6.8 kΩ series resistance per DIN 45 596

Operating Voltage

SCM800: 120 Vac rated nominal (see *Voltage Selection* for 230 Vac operation), 50/60 Hz, 200 mA

SCM800E: 230 Vac rated nominal (see *Voltage Selection* for 120 Vac operation), 50/60 Hz, 100 mA

Temperature Range

Operating: 0° to 60° C (32° to 140° F)

Storage: -30° to 70° C (-22° to 158° F)

Overall Dimensions

44.5 mm H x 483 mm W x 317 mm D (1³/₄ x 19 x 12¹/₂ in.)

Net Weight

4.3 kg (9 lb 9 oz)

Certifications

SCM800: Listed by Underwriters Laboratories, Inc.; listed as Certified by Canadian Standards Association

SCM800E: Conforms to European Union directives; eligible to bear CE marking; VDE GS-Certified to EN 60950;

EU EMC Immunity Requirements: EN50082-1

REPLACEMENT PARTS

Knob, Channel Gain & Phones (white) 95A8238

Knob, Master (blue) 95B8238

Line (Power) Cord (SCM800) 95A8389*

Line (Power) Cord (SCM800E) 95A8247*

Link Cable 95A8889

Three -Terminal Block Connector 95A8580



ER-16RB

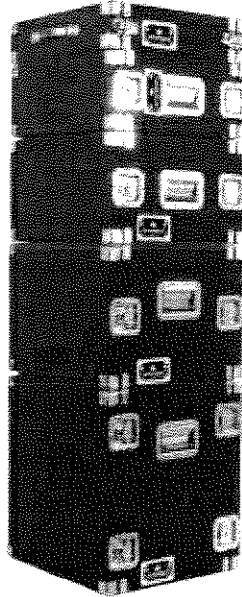

Grundorf's ER-16R Carpet Series Equipment Rack has a 16" rackable depth and a rack body depth of 16.5". With the front and back covers on, it measures 20.25" deep outside.

The ER-16R has 16 rack spaces (28"). It comes standard with 8 heavy-duty, recessed catches, 2 heavy-duty recessed handles, corner clamps for extra strength, metal corners and metal bottom feet.

Specifications:

* Dimensions: 29.75" H x 20.75" W x 20.25" D (755.65 x 527.05 x 514.35 mm)

* Weight: 44.0 lbs. (19.8 kg)



75-103

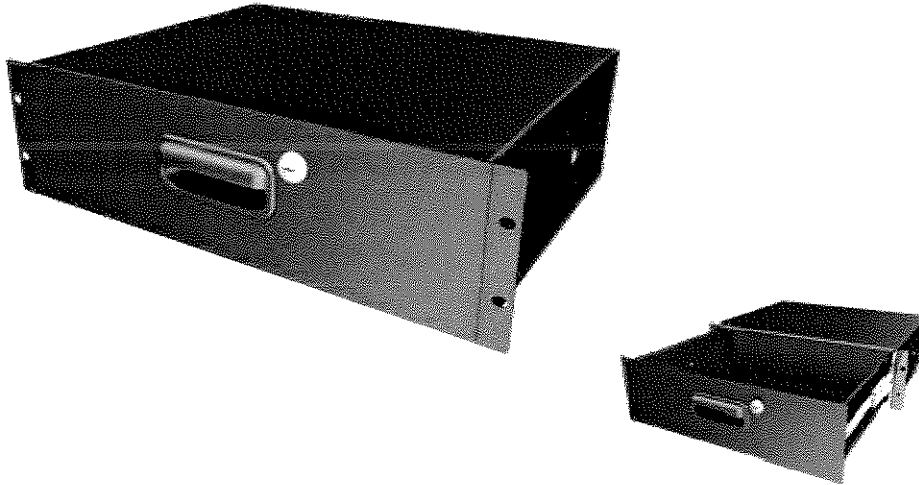

Description

Drawer 3 Space

Key Lockable

1.5mm metal Black

H - 5.25" W - Rack Mount D - 13.75"

Specifications

Spacing: 3

Dimensions: H - 5.25" D - 13.75"

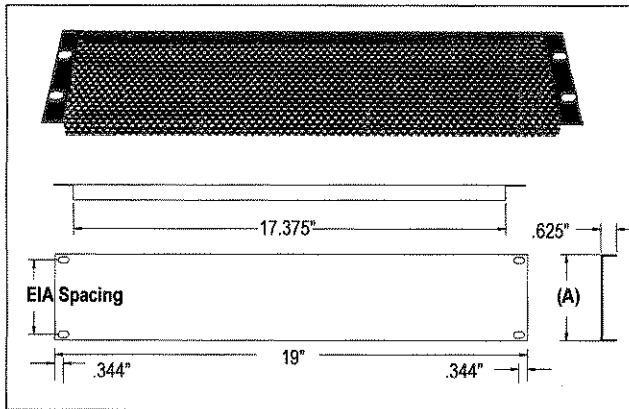

Vented Steel Panels - Perforated - L5 Series

Lowell L5 Series vent panels are perforated 20 gauge steel with a .625" flange for strength and rigidity. L5 Series are finished in smooth semi-gloss black powder epoxy paint for durable and scratch resistant performance. Attractive panels with fine-perforated .0781" holes on 1/8" staggered centers are ideal for providing heat ventilation and protection for equipment mounted in EIA standard racks.

For ordering convenience, panels are sold in single units and bulk contractor cartons. Panel mounting screws in a variety of head styles are available to meet application needs; see page 2.

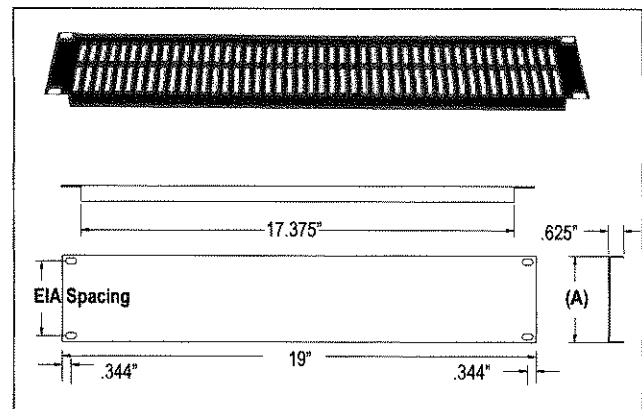

Vented Steel Panels - Slotted - L6 Series

Lowell L6 Series vent panels are slotted 16 gauge steel with a .625" flange for strength and rigidity. L6 Series are finished in smooth semi-gloss black powder epoxy paint for durable and scratch resistant performance. Rugged panels with 0.125" x 1.25" obround slots on .375" centers provide heat ventilation and protection for equipment mounted in EIA standard racks.

For ordering convenience, panels are sold in single units and bulk contractor cartons. Panel mounting screws in a variety of head styles are available to meet application needs; see page 2.

Steel (20ga.) Perf (flanged) Models	(A) Panel Space (Inches)	(A) Panel Space (Rack Units)	Powder Finish	Pack Qty
L5-191	1.75"	1RU	Smooth Black	1
L5-193	3.5"	2RU	Smooth Black	1
L5-195	5.25"	3RU	Smooth Black	1
L5-197	7"	4RU	Smooth Black	1
L5-198	8.75"	5RU	Smooth Black	1
L5-1910	10.5"	6RU	Smooth Black	1
L5-1912	12.25"	7RU	Smooth Black	1
L5-1917	17.5"	10RU	Smooth Black	1



Single pack models

Steel (16ga.) Slot (flanged) Models	(A) Panel Space (Inches)	(A) Panel Space (Rack Units)	Powder Finish	Pack Qty
L6-191	1.75"	1RU	Smooth Black	1
L6-193	3.5"	2RU	Smooth Black	1

Steel (20ga.) Perf (flanged) Models	(A) Panel Space (Inches)	(A) Panel Space (Rack Units)	Powder Finish	Pack Qty
L5-191CC	1.75"	1RU	Smooth Black	12
L5-193CC	3.5"	2RU	Smooth Black	12
L5-195CC	5.25"	3RU	Smooth Black	6
L5-197CC	7"	4RU	Smooth Black	6

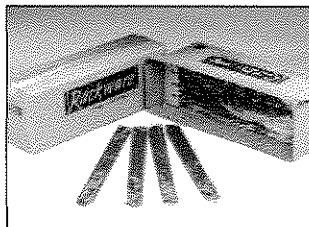

Bulk quantity models
"Contractor & Master Cartons
for large jobs and distribution

Steel (16ga.) Slot (flanged) Models	(A) Panel Space (Inches)	(A) Panel Space (Rack Units)	Powder Finish	Pack Qty
L6-191CC	1.75"	1RU	Smooth Black	12
L6-193CC	3.5"	2RU	Smooth Black	12

JG8 SERIES



STANDARD POWER DISTRIBUTION CENTERS

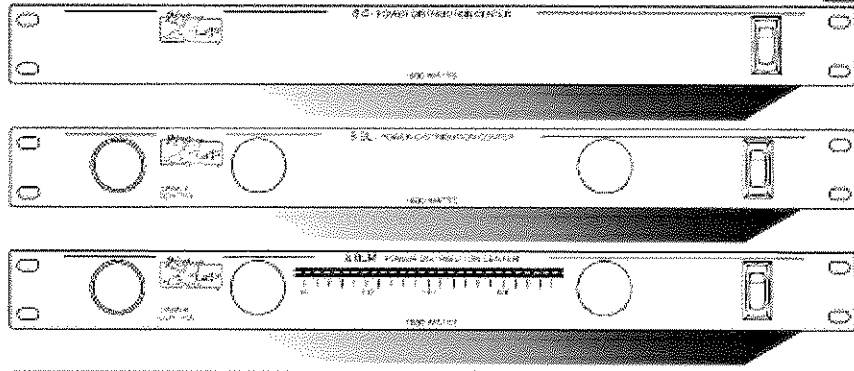

JG 8.0, 8.0L & 8.0LM

The JG8 Series family of power and light modules includes three great, economical models that are valuable accessories for any rack mounted system. The eight switched AC power outlets on the back of each unit provide a full 1800 watts of power while the discreet components inside provide a base level of equipment protection against dangerous voltage spikes. JG8 Series products are designed, produced and priced to provide quality and convenience within the limits of an everyday budget. Plus, the outlets on the back are rotated to better accommodate “wall wart” power supplies.

LIGHTS The JG8.0L and JG8.0LM feature two metal encased, slide out light modules. These lights can be dimmed and rotated to control the intensity and direction of the two light beams. After use, the lights slide into the chassis to store conveniently away. The “night light” style bulbs install from the front of each light tube assembly.

LINE NOISE AND SPIKE PROTECTION In March 2003 Juice Goose tripled the level of power protection in the JG Series products. The models now provide base level component protection across all three incoming power leads to help reduce annoying AC line noise and protect against high voltage spikes that can damage equipment. A matrix of three fast acting metal oxide varistors combined with a frequency interference filter capacitor work to clean the AC.

THREE YEAR WARRANTY Every JG Series product is manufactured to exact Juice Goose specifications. Every JG Series product is subjected to a complete functional test before shipping. And every JG8 and JG11 Series product packs a 3 year warranty and the full backing of the best name in power products, Juice Goose

SPECIFICATIONS

INPUT VOLTAGE	120vac, 60 Hz
CURRENT CAPACITY	15 Amps (approx. 1800 Watts)
DIMENSIONS (inches)	1.75H x 19W x 7D
WEIGHT	5 to 6.5 lbs
CHASSIS	Steel with aluminum tubes
POWER CORD	6 Foot 16/3 SJT
POWER OUTPUT CONNECTORS	Eight NEMA 5-15, 15 Amp Rating
CURRENT OVERLOAD PROTECTION	Circuit Breaker, 15 Amp Thermal on Rear
AC LINE FILTRATION	Line Capacitor (Line & Neutral)
VOLTAGE SPIKE PROTECTION	Triple Metal Oxide Varistor Matrix



RDL[®]
Radio Design Labs

SPECIALISTS IN PRACTICAL PRECISION ENGINEERING™

STICK-ON[®] SERIES

Model STM-DA3

Mic Level Distribution Amplifier

ANYWHERE YOU NEED...

- To Feed 1 Microphone to 3 Mic Inputs
- Electrical and Audio Isolation
- Ultra Low-Noise
- Ultra Low-Distortion
- Excellent Phase Response
- Versatility of STICK-ON Compactness
- RDL's Exclusive Dual LED VU Metering

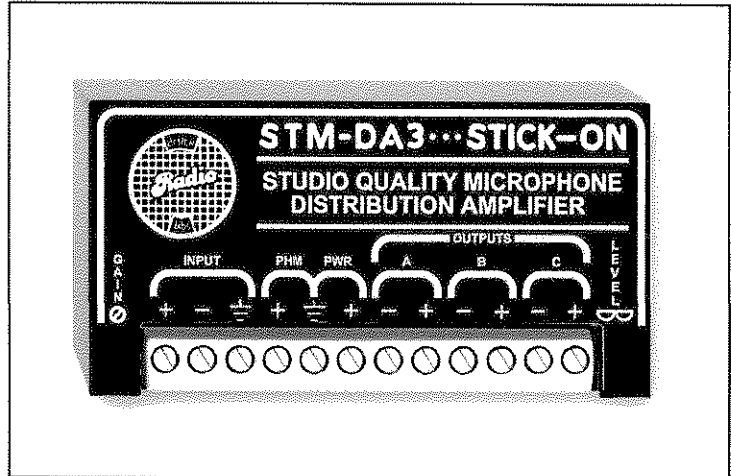

You Need STM-DA3!

The STM-DA3 is part of the group of versatile STICK-ON products from Radio Design Labs. STICK-ONS feature the advanced circuitry for which RDL products are known, combined with unequalled versatility in mounting possibilities. The durable adhesives provided with the STM-DA3 permit permanent or removable mounting. Numerous available mounting accessories, brackets and rack-mount chassis are optionally available to facilitate any system design.

APPLICATION: The STM-DA3 is designed for use in quality commercial sound, broadcast and recording applications. The 1200 Ω balanced input accepts a wide variety of microphone input levels without loading professional low-impedance microphones. A multi-turn trimpot is user adjustable for either gain or loss in order to match the facility standard microphone levels. Three balanced outputs provide nearly total isolation between the output lines. Unlike mic-splitting transformer systems, the STM-DA3 also provides audio isolation. In fact, the audio isolation is so good that a +4 dBu signal fed into one output is still below the noise floor on the adjacent output. Loading of one output, including a direct short, has no effect on the other outputs.

The STM-DA3 is built on the electrical architecture of RDL's low-noise studio-quality mic preamplifiers. Dynamic or condenser microphones may be used with the STM-DA3. Standard 24V phantom is supplied to the input when the supply voltage is connected to the PHM terminal. Optimum operating level is set using RDL's unique dual LED VU meter, located adjacent to the terminal block. A green LED illuminates at 15 dB below optimum level. The intensity of the green LED progresses from minimum to full intensity over a 15 dB range. The adjacent red LED illuminates when the operating level exceeds the optimum level. This makes the STM-DA3 easy to set up without any external test equipment, and operating levels may be monitored at the module.

Wherever a microphone distribution amplifier is needed, the STM-DA3 is the ideal choice. Use the STM-DA3 combined with other RDL products as part of a complete audio/video system.

STICK-ON[®] SERIES

Model STM-DA3

Mic Level Distribution Amplifier

Installation/Operation



EN55103-1 E1-E5; EN55103-2 E1-E4
Typical Performance reflects product at publication time
exclusive of EMC data, if any, supplied with product.
Specifications are subject to change without notice.

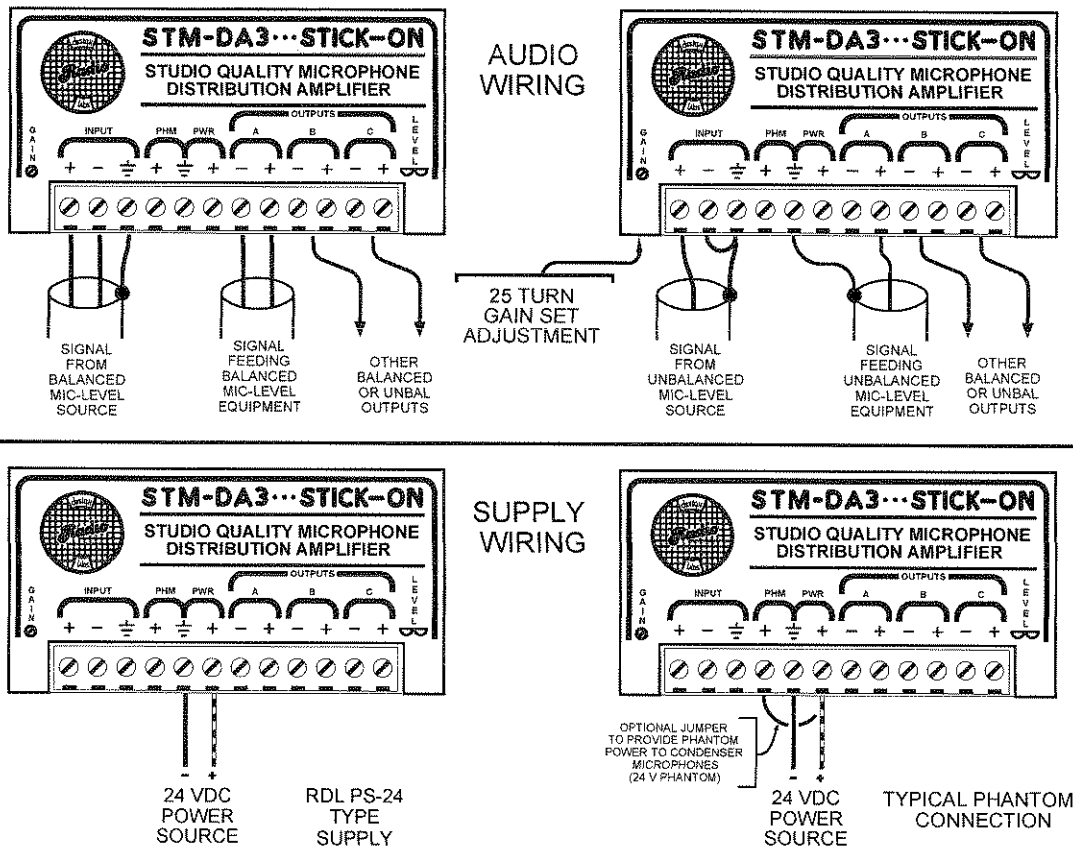

TYPICAL PERFORMANCE

Input:	1200 Ω balanced
Outputs (3):	-45 dBu, 150 Ω balanced
Gain Range:	17 dB, 10-turn trimmer adjustable:
Control fully CCW:	Gain = -5 dB
Control fully CW:	Gain = 12 dB
Frequency Response:	30 Hz to 20 kHz (+/- 0.2 dB)
THD:	< 0.1%
IMD:	< 0.1%
Noise:	<80 dB (below -50 dBu output, -45 dBu input)
Headroom:	> 20 dB (-50 dBu output, -50 dBu input)
CMRR:	> 60 dB (100 Hz to 5 kHz)
Output Isolation:	> 135 dB (balanced audio), > 150 dB (common mode)
Power Requirement:	24 - 33 Vdc @ 40 mA, Ground-referenced

Professional Solid State Recorder **PMD560**

For the past several years, Marantz Professional solid state recorders have been revolutionizing the worlds of broadcasting, journalism, and portable professional recording. With no moving parts, solid state technology has virtually made repair and maintenance a thing of the past. Now, Marantz Professional brings the flexibility and reliability of this format to the installation market at an affordable price-with the PMD560.

More and more, audio is being delivered online, through email, web-casts, and pod-casts. Even CD recording-once the "hip new thing,"-has become the de facto standard. The equipment you install has to be capable of rendering your audio in the high-quality digital formats that end users want, need, and frankly expect.

The PMD560 is designed precisely for this purpose. Mounting into an economical 1U rack space, the PMD560 records audio directly to an inexpensive Compact Flash card. It can easily be configured to record mono or stereo in two of the most common data formats, PCM (uncompressed) and .mp3. If you use more than one format, the PMD560 offers three programmable presets for your favorite setups-

Key Features

- Solid State Design
- No moving parts-no maintenance
- Records uncompressed 16-bit PCM .wav files at 44.1 kHz or 48 kHz.
- Records mono .mp3 files at 64 kbps
- Records stereo .mp3 files at 128 kbps
- 3 Presets allow instant configuration of recording format
- Uses inexpensive, widely available Compact Flash media (CF)
- A 1 GB CF card can hold over 1 hour of uncompressed stereo
- A 1 GB CF card can hold over 17 hours (stereo) or 36 hours (mono) .mp3
- RCA line I/O
- "Copy Segment" cut-and-paste editing to a new sound file
- 99 "Virtual Tracks" for EDL-style editing
- Front Panel USB port for easy file transfer
- RS-232 port for automation and machine control

Solid State Technology

By storing audio data on Compact Flash (CF) media cards, all of the mechanical hassles of tape recorders are gone forever-as are the costs of servicing and maintaining them. Not only that, but CF storage allows you to choose different recording formats, and makes transferring audio files to computers a snap.

Long Record Times

No more flipping tapes! A single 1 GB flash card can hold up to 36 hours of uninterrupted audio (monaural .mp3 at 64 kbps). For music recording, the same size card can hold more than 17 hours



press one key, and the PMD560 is configured to your specifications. RS-232 is provided for machine control and automation, and editing and playlist creation can be done directly from the front panel. Marantz Professional has even included a USB connector right on the front panel to facilitate transfer of sound files to your PC..

See? We told you we were paying attention.

high-quality compressed stereo (.mp3 at 128 kbps). If you need the unmatched quality of uncompressed audio, you can get about one-and-a-half hours worth of 16-bit linear PCM audio at 44.1 kHz or 48 kHz on the same 1 GB card.

Editing and File Transfer

Using older technology, preparing your final product was an involved process, sometimes involving multiple steps of transfer and format conversion. With the PMD560, you record in the format you need, and moving that recording to a computer is easy. In some cases, it's as simple as pulling the CF card from the PMD560 and plugging it into the card reader on your computer. Alternatively, you can use the USB port on the front panel to transfer audio files to a PC. It's already in your format of choice, so once it's in your computer, it's ready to post to the web, burn to a CD, or edit in your favorite editor.

Exclusive-"Virtual Track" Mode

In addition, you can make your edits and playlists right on the PMD560. Marantz Professional's exclusive "Virtual Track" mode allows you to create up to 99 virtual tracks-internal playlists of audio segments. You simply tell the PMD560 what segments of a file to play, and in what order, and it does it-without altering the original file in any way, and without using up more card memory. Need to webcast part of a meeting to your sales team? Want to play a few interview segments during your presentation? What about podcasting the six best songs from the holiday concert? Editing is easy with virtual tracks.

PMD560



Specifications

Digital audio system

System	Solid State Recorder
Usable media	CF memory cards Microdrive

Recording and media methods

mp3	MPEG1 Layer III compression
PCM	16 bit linear PCM

Recording bit rate

MP3 mono	64 kbps
MP3 stereo	128 kbps

Sampling frequency

Number of channels	2 (stereo), 1 (mono)
Frequency response	20Hz to 20kHz(+0dB, -2.0dB)

Signal-to-Noise Ratio

IEC-A weighted	86 dB
----------------	-------

Total harmonic distortion at 0 VU (PCM)

	0.01%
--	-------

Dynamic range

	86db
--	------

Inputs

LINE IN

Type	RCA jack
Input sensitivity	500 mVrms/22 kohms

Outputs

LINE OUT

Type	RCA jack
Standard level	2.0 Vrms /300 ohms

General

Headphone output power	20 mW/ 32 ohms
Power requirement	AC 100-AC230V
Americas model	AC 120/ 60Hz
Power consumption	12w

Dimensions

Width	19 in (482.6 mm)
Height	2 in (52 mm)
Depth	11.7 in (298 mm)
Weight	6.6 lbs (3.0 kg)

Included accessories

Power cord	1
USB cable	1
Audio cable	2
Screws (ISO 3x10 mm)	2
Plastic pin and retainer	1
CD-ROM	1
User Guide	1

Optional accessories

(See www.d-mpro.com for description and/or ordering information)

Wired remote	RC600PMD
--------------	----------

PLEASE NOTE: Specifications are based on measurement conditions and proper care for the machine, and are subject to change without notice.

D&M Professional
1100 Maplewood Drive Itasca, Illinois 60143
Tel: 630.741.0330 Fax: 630.741.0652
www.d-mpro.com

© 2004 D&M Professional. All Rights Reserved.

DENON
PROFESSIONAL

marantz
PROFESSIONAL

LEVEL

SanDisk

SanDisk ImageMate Multi-Card USB 2.0

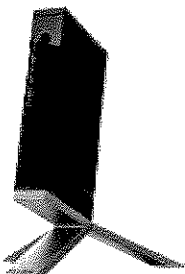

Bay Required Type: None

Header Compatibility: Mac , PC Manufacturer: SanDisk Model: Multi-Card USB 2.0
Packaged Quantity: 1 Product Line: SanDisk ImageMate

Interface Provided Type: None

Interface Required Connector Type: 4 pin USB Type A Total Qty: 1 Type: Hi-Speed USB

Memory Adapter Device Type: Card reader Enclosure Type: External Interface: Hi-Speed USB Supported Flash Memory: Memory Stick , Memory Stick PRO , MultiMediaCard , MultiMediaCardmobile , MultiMediaCardplus , RS-MMC , SD Memory Card , SDHC Memory Card , xD-Picture Card , xD-Picture Card Type H , xD-Picture Card Type M

Miscellaneous Included Memory Adapter Accessories: Stand , USB cable

Slot Required Type: None

System Requirements Min Operating System: Apple MacOS X 10.3 , Apple MacOS X 10.4 , Apple MacOS X 10.5 , Microsoft Windows 2000 , Microsoft Windows Vista , Microsoft Windows XP

RAM Type: None

**LAKESIDE PLANTATION
COMMUNITY DEVELOPMENT DISTRICT**

District Office ♦ 2002 North Lois Avenue ♦ Suite 507 ♦ Tampa, Florida 33607 ♦ (813) 873-7300 ♦ Fax (813) 873-7070

To: Board of Supervisors
From: Brian K. Lamb
Date: September 15, 2010
Re: Clubhouse Report

The renovations are complete to the clubhouse and you will find a summary of expenses attached to this memorandum. In addition to what was contracted we would recommend that an amount NTE of \$4,000 be approved to update the wall paper, paint and ceiling fans in the main gathering room.

CLUBHOUSE REMODEL

Original Contract with Teixeira Construction	\$21,263.00
Add Mirrors in Room	840.00
Credit for Folding Door Allowance	(400.00)
Electrical Allowance Credit	(19.00)
Wood Floor Allowance	233.00
Security Wiring Allowance	280.00
Sprinkler System Allowance	<u>150.00</u>
	\$22,347.00
Total Paid to General Contractor	\$22,347.00
Wallpaper Material	449.80
Wallpaper Labor, Strip & Paint	<u>975.00</u>
ROOM TOTAL	\$23,771.80
Approved Amount	\$23,000.00
5% Extra	<u>1,150.00</u>
Total Amount Approved	\$24,150.00
Amount Budgeted	\$24,150.00
Total Cost	<u>\$23,770.00</u>
UNDER BUDGET	378.20

**LAKESIDE PLANTATION
COMMUNITY DEVELOPMENT DISTRICT**

District Office ♦ 2002 North Lois Avenue ♦ Suite 507 ♦ Tampa, Florida 33607 ♦ (813) 873-7300 ♦ Fax (813) 873-7070

To: Board of Supervisors
From: Brian K. Lamb
Date: September 15, 2010
Re: Pool resurfacing recommendation

Staff has received three proposals to resurface the pool as attached, we recommend Fountain Pools at a price NTE \$30,000 with a commencement date of November 1st, to be complete within 3 weeks.

Aqua Doc, Inc. - dba
CPC 057098

Fountain Pools

Water features

12410 TAMiami TRAIL
PUNTA GORDA, FL. 33955

888-458-3701
941-575-9606 fax
E-Mail fountainpools@hotmail.com
www.fountainpoolswf.com

Date: 7/30/2010

We hereby submit specifications and estimates to:

Name: Robert Babik

Address: 1979 Scarlett Ave. North Port

Phone: 941-626-1820

PROPOSAL FOR RENOVATION OF COMMUNITY CLUB HOUSE

POOL:

Drain and Acid Wash Pool

Undercut all Plumbing and Drains

Repair Existing Damages to Pool

Install New 2" x 6" Bullnose Non-Skid Tile around Perimeter of Pool and Steps (Choice of Colors)

Install Sunstone Exposed Aggregate Interior Finish (Choice of Colors)

Fill and Balance Pool

Grading of all areas disturbed by Construction Included: ----- \$22,300.00

Upgrade Interior Finish to Wet Edge Technologies (Pebble): ----- \$7,600.00

29,900

SPA:

Drain and Acid Wash Spa

Undercut all Plumbing and Drains

Repair Existing Damages to Spa

Install New 2" x 6" Bullnose Non-Skid Tile on Steps and Bench (Choice of Colors)

Install Sunstone Exposed Aggregate Interior Finish (Choice of Colors)

Fill and Balance Spa: ----- \$1,200.00

Upgrade Interior Finish to Wet Edge Technologies (Pebble): ----- \$450.00

1650

(Spa price is based on refinishing both pool and spa)

NOTE:

+ 80,000 Gallons of Water

#1 23,500

#2 31,550⁰⁰

robert

From: Aaron Appolloni [aaron@fountainpoolswf.com]
Sent: Monday, August 02, 2010 8:44 AM
To: babak1975@comcast.net
Subject: [Fwd: Fountain Pools]
Attachments: Babik.docx

My mistake I typed in the wrong email address.

Bob,

Good afternoon, please see attachment for proposal to resurface community pool and spa. If you have any questions please call me on my cell or reply via email.

I have discussed this project with the owner and this is something that we can and will complete in one week. If you would like to see some of our commercial projects I will be glad to send you info with contacts and addresses.

Have a good weekend, I will wait to hear from you.

Aaron Appolloni
(239)-989-9844
Fountain Pools and Water Features
12410 Tamiami Trail, Punta Gorda Fl 33955

Aaron Appolloni
(239)-989-9844
Fountain Pools and Water Features
12410 Tamiami Trail, Punta Gorda Fl 33955

Indigo

Swimming Pools & Spas, Inc.
3216 Ambrosia Terrace North Port, FL 34286
230 South Tamiami Trail Suite 3A, Venice, FL 34286

Phone 941-423-5600
Fax 941-429-6651

LIC# CPC145777
FL State Contractor License

4/13/2010

Lakeside Plantation CDD

Attn: Robert Babik
2200 Plantation Blvd.
North Port, FL 34289

Commercial Pool Renovation Specifications:

- Drain and acid wash pool
- Remove delamination of old pool finish (includes up to 25% of existing finish)
- Install new 6 inch gutter edge tile around entire perimeter of swimming pool
- Install new non-skid edge tile on shallow end steps and non-skid belly band tile across dividing line in pool
- Prepare swimming pool surface with bond coating
- Install new floor inlet covers, main drain covers, and new gutter grates – repack around all inlets with hydraulic cement
- Balance pool chemicals once filled
- Arrange for final inspection with Health Department before reopening of pool
- Keep jobsite clean with final debris removal at completion of project
- Pressure clean pool deck area once complete

Total for above described project with PebbleTec(White Pearl) \$27,000.00
Additional amount to resurface spa with pool \$3,250.00
 PebbleTec carries a specific commercial pool warranty of 5 years material and labor

22

Total for above described project with Sunstone (White Pearl) \$23,500.00
Additional amount to resurface spa with pool \$2,850.00
Sunstone carries a standard warranty of Lifetime Materials and Labor

26,350

#1

Total for above described project with KrystalKrete \$19,500.00
Additional amount to resurface spa with pool \$2,650.00
KrystalKrete carries a specific commercial warranty of 10 years materials only

22,150

Surface delamination in excess of 25% to be added at a calculated rate of .75 cents per square foot. Pool total surface area is 3315 – *Maximum amount not to exceed \$1864.69*

Payment Terms:

25% Initial Deposit, 25% due upon tile installation, Final balance due upon completion

Customer Signature: _____ Date _____

Notes

22,150
 # 26,350
 4 80,000 Gallons of water

Indigo

Swimming Pools & Spas, Inc.

3216 Ambrosia Terrace, North Port, FL 34286
230 S. Tamiami Trail Suite 3A, Venice, FL 34285

Phone 941-423-5600
Fax 941-429-6651

LIC# CPC1457777
FL State Certified Contractor

To: Lakeside Plantation

5/6/2010

Homeowners Association Board and the homeowners in which it represents.

The following are three commercial references for projects I have done. Each one represents the three different interior finishes that we have proposed for your project. Please feel free to make contact with the representatives at each project. I have let them know that you may be calling and may want to see the pool and the finish in which we applied to their surfaces.

Freedom Village – Bradenton. Jeni Tomason 941-798-8152

PebbleTec White Pearl interior pool finish, new tile on entire pool. This pool was on its third resurface and all the previous layers had to be removed before installing new finish.

Promenades East – Port Charlotte. Terry Owens 941-627-6880

Krystal Krete interior finish, new tile, ladders and rails.

Lido Beach House – Sarasota. Diane Green 941-928-0100

Sunstone White Pearl interior finish. Small condo association pool.

Thank you again for the opportunity,

Pat Ireland
Indigo Swimming Pools and Spas, Inc. - President

Allbright Plastering Inc. Proposal

TO: Lakeside Plantation Attn: Bob Babik
 2200 Plantation Blvd
 North Port, Fl 34289

Phone: 626-1820 Date: 6/18/2010
 Job Name:
babik1975@comcast.net
 Secondary Phone:

We hereby submit specifications and estimates for: **Resurface Swimming Pool, Spa and Gutter**

- 1 Cover existing pool deck to protect from construction debris.
- 2 Drain pool and spa.
- 3 Remove existng 6" x 6" gutter tiles in pool only.
- 4 Form and flash tile beam in pool using portland, masonry and sand mix.
- 5 Install 6" x 6" mud cap tiles per code.
- 6 Chisel around all floor and wall inlets including light niches in pool and spa.
- 7 Water-proof around all wall inlets and light niches in pool and spa prior to resurfacing.
- 8 Install 2" x 6" dark contrasting flush caps on floor and wall of swimming pool between shallow and deep ends.
- 9 Install new scum gutter frame and grates (27).
- 10 Acid bath pool and spa in preparation for bond kote application.
- 11 Bond kote pool and spa for mechanical bonding.
- 12 Reset step and bench tiles in pool and spa using non skid 2" x 6" mud caps per code.
- 13 Install VGB approved main drain frame and grates (2) in pool and (1) for spa
- 14 Resurface pool and spa using standard stone finish (White Pearl with limited lifetime warranty).
- 15 Chemicalize to standards.

We propose hereby to furnish material and labor-complete in accordance with the above, for the sum of:
Total: \$29,537.00

- Payment to be made as follows:
- \$ \$4,000.00 When pool and spa are drained and waterline tiles are removed from pool.
 - \$ \$6,000.00 When 6" x 6" mud cap tiles are installed in pool.
 - \$ \$4,000.00 When pool is bond and spa are koted and ready for new surface.
 - \$ \$12,000.00 When pool and spa finishes are installed.
 - \$ \$3,537.00 Upon completion.
 - \$ Selected options will be paid upon the completion of each.

All agreements contingent upon strikes, accidents, or delays beyond our control. Our workers are fully covered by worker's compensation insurance. Exposed aggregate finishes are water exposed and some loss of aggregate is expected this is not to be considered a failure. It is understood that stone application techniques can result in color variations in tone and appearance. This variation in pool shades is not to be considered a failure. Stone applications are not guranteed with regard to color. The contractor shall have the right to repair the area of failure only. Material replacement is limited to this repair and it is understood that some cosmetic variation may result. Any controversy arising out of or relating to this agreement shall be submitted to arbitration through the National Spa & Pool Institute.

Acceptance of Proposal -

The above prices, specifications, and conditions are satisfactory and are hereby accepted. You are authorized to do the work specified. Payment will be made as outlined above.

Authorized Signature: _____

Note: This proposal may be withdrawn by us if not accepted within _____ days

Signature: _____

Date of Acceptance: _____ Signature: _____

Attn: Bob Bobbick



144 Triple Diamond Blvd.
Unit E
N.Venice, FL 34275-3631
(941) 488-3990

Estimate

DATE	ESTIMATE NO.
6/14/2010	10-99



Thank You for Voting
"The Best of Venice"!

NAME / ADDRESS
Lakeside Plantation 179 Toledo Blade Blvd. North Port, FL 34288

PROJECT

ITEM	DESCRIPTION	COST	TOTAL
Pool	Replaster Pool using Krystal Krete Quartz with 10 Year Warranty (choice of colors), Replace Step Tiles with anti slip tiles, Replace Pool Waterline Tile, Replace Belly Band Tile Line, Replace Gutter Grates, Replace Pool Main Drain Cover (if necessary), Replace Covers on Bottom Pool Returns.	14,016.00	14,016.00
Spa	Replaster Spa with same options as Pool Price does not include retiling of Gutter Back Splash (It is in good condition) Does not include Chemical Start up upon completion Quote is subject to additions determined by Health Department Survey.	1,296.00	1,296.00
Estimate Good for 30 Days.		TOTAL	\$15,312.00

NOTE: + Water 30,000 Gallons

DISCUSSION OF STANDARD PACIFIC ROAD REQUEST

Good afternoon CDD and HOA Board members. I hope this finds you all well. I have spoken further with our VP's. The reasoning given for not proceeding with the paving at this time was money; however, after further discussion, we decided it might be best to get this obligation off our books this year. That being said, StanPac may be in a position to move forward based on the following:

1. The HOA and CDD Boards agree that once the paving is completed by StanPac and accepted by the CDD, the CDD then becomes responsible for the roads.
2. There are no further obligations of Standard Pacific as far as the developer.
3. Realizing that the CDD wants some type of "commitment of repairs from damage" from any further construction work, we must all agree that the responsibility of any damage caused by construction would be whoever owns those vacant lots and hence is performing the construction on their behalf. Should StanPac decide to move forward and build the remaining units (which is highly unlikely at this point), StanPac would be responsible for repairing any damages caused by construction activities. However, if StanPac sells the lots to another owner/investor, the obligation transfers to the new owner of those lots.
4. As we would want this check cut by the end of December, we would propose that repairs be scheduled for early or mid November when (a) the weather is a bit cooler, and (b) the board members who live up north are down and would be available to assist with coordinating the parking/towing efforts, etc. This is going to take some coordination by SunVast, the contractor and the Board to pull this off efficiently. I would imagine the contractor would split the community in 2 or 3 sections and do a different section each day. That would leave the remaining 1/3 or 2/3 of the community for folks to park in the street while a section is being paved. I say that because we all know that owners are NOT going to park in the CDD pool parking lot and walk to their units. As this activity is going to affect your owners, we are willing to let you dictate to a point how and when you would like this done, as long as the contractor concurs and it does not run up the cost any higher than the bids we have already received.

If the CDD and HOA Boards are agreeable to all of these terms please advise and we can contact the contractor to schedule this work. We do realize that everyone is anxious to have this work completed and we really appreciate your patience. Let us know if these terms are agreeable and if there is any particular week that you might want this work scheduled for.

Thanks everyone and have a wonderful holiday.

Debora L. Hudrlik, AMS, CMCA
Community Association Manager
Standard Pacific Homes
405 N. Reo St., Ste. 330
Tampa, FL 33609
Phone: 813-288-7742
Fax: 813-288-7747
DHudrlik@stanpac.com

From: John and Judy [mailto:jandjrice@chartermi.net]
Sent: Thursday, August 26, 2010 2:51 PM
To: Debi Hudrlik
Subject: Re: Towns - Road Paving

Debi: THANKS for your response albeit disappointing to relay about the asphalt paving. While respecting the decision, it would be helpful for our Board to know the reasons/rationale.....sometime soon. And yes, we'd like to know more about the status of the vacant lots. Thanks for your continuing support of the Towns at Lakeside.....glad that you are very busy.....and, if in the North Port area after November 1 (snowbird time!) do not hesitate to give me a shout...for a short visit! John

----- Original Message -----

From: [Debi Hudrlik](#)

To: [John and Judy](#)

Cc: [James Ro](#)

Sent: Thursday, August 26, 2010 10:36 AM

Subject: RE: Towns - Road Paving

Hi John, all is very very busy here. Our division president has elected not to move forward with the second coat of asphalt at The Towns at this time. Should any potholes develop in the interim, James can advise us and we will pay for repairs. When Barry comes back from vacation I will check with him as far as a status on the vacant lots.

Debora L. Hudrlik, AMS, CMCA
Community Association Manager
Standard Pacific Homes
405 N. Reo St., Ste. 330
Tampa, FL 33609
Phone: 813-288-7742
Fax: 813-288-7747
DHudrlik@stanpac.com

From: John and Judy [<mailto:jandjrice@chartermi.net>]

Sent: Monday, August 16, 2010 5:38 PM

To: Debi Hudrlik

Subject: Towns - Road Paving

Hi Debi: Hope all is going well! How about an update on the status, discussion, pro's/con's about finishing the paving of our roads? Thanks, John



September 14, 2010

Bob Babik
Lakeside Plantation HOA

RE: Recommendation for Operation of Fountains in Present State

Bob,

After a thorough inspection and rigorous testing of your entry fountains, I do not recommend that they be operated in their present condition. The minimum requirement to make the fountains operate is to replace the pump manifolds in the equipment vault. This is necessary because of to the extreme corrosion and the danger of flooding the vault if there is a catastrophic failure. The cost to rebuild both of the custom manifolds would be approximately \$9,025. The manifolds contain a total of (2) 8" butterfly valves, (8) 3" butterfly valves and (2) 3" check valves. One of the pump motors operated intermittently when we were there. If it fails, the cost to replace a 7.5 HP motor would be approximately \$3,000.

Once the manifold is fixed, we will be able to test the lines between the equipment vault and the fountains for leaks. Depending on the presence and locations of leaks, we will be able to estimate the cost to repair the lines.

The tiles and finishes are permanently discolored. The estimated price to remove and replace the finishes will be about \$9,000 - \$11,000 per fountain.

The leak in the equipment vault cannot be repaired because the other side of the cracked fiberglass is encased in concrete. There is a risk of electrical shock if the vault floods and the electrical components are immersed in water. I am concerned that the sump pump must operate constantly to keep the groundwater from filling the vault. The sump pump discharge should be moved farther from the vault.

The fountain structure has many cracks and we could not warrant any repairs, therefore I do not recommend any.

I hope this information is helpful. Please call me to discuss.

Very truly yours,

Myriam Murphy, P.E.
HazelTine Nurseries, Inc.
2401 North River Road, Venice, FL 34292
Tel: (941) 488-8820 x 138
Email: mmurphy@hazeltinenurseries.com



Bob Babik
 Lakeside Plantation HOA
 North Port, FL
 Tel: (941) 626-1820, Email: babik1975@comcast.net

August 25, 2010

RE: Lakeside Plantation Entry Fountains – Revised Proposal

Hazeltine Nurseries, Inc. is please to offer an alternate quote for the fountains. I believe the following design offers a good value and an exciting water display.

If you choose Hazeltine Nurseries, Inc. (HNI) to construct the fountains, we will be solely responsible for the execution of the work in compliance with the plans, specifications and municipal building codes.

The scope of work to create the plans is the subject of the design contract, which I sent you previously.

The scope of work I propose does not include the demolition of the existing fountains.

Water Display for Entry Fountains

We propose a new poured concrete fountain basin, 15' outside diameter, with (6) nozzles. The center of the fountain will contain a 3" cascade jet shooting a frothy column of water to a height of 5' – 6'.

It will be surrounded by (5) 1-1/2 cascade jets shooting water to a height of 3' – 4'.

Each jet will have a submersible light, 250-watt, for nighttime illumination.

Equipment

The fountain pumping, control and filtration system will be enclosed in a fiberglass subterranean vault with lockable lid. We propose a separate equipment vault for each fountain. This will eliminate the need to run a pipe under the roadway and the need to completely demolish the existing vault.

Pumping System

Water is pumped to the fountain from a 5 HP feature pump, through a discharge manifold and through (6) nozzles in each fountain.

Automatic Refill

Fresh water enters the system when the water level drops below a preset level.

Filter System

Water is returned to the equipment vault from (2) drains in the fountain floor. The drains are sized and vented to prevent the possibility of suction entrapment. Part of the returned water is filtered through a 20-micron cartridge filter by a 1 HP recirculation pump with hair and lint strainer. It passes through an erosion feeder, which adds a sanitizing agent to the water to prevent biological growth. The filtered water returns to the fountain basin through floor outlet fittings arranged to push any debris toward the drains. A skimmer in the fountain wall removes floating debris.

Water Source and Drain

The water source is a 1" line from a municipal water meter. The drain will connect to a storm or sewer line, as directed by code. These connections are not included in this proposal and must be made by a licensed plumber.

Installation

This includes all tasks and materials to provide a completely operational fountain system as described in the construction documents approved by the HOA.

1. Mobilization
2. Lay Out – on-site layout of fountain structures.
3. Form Work – Set the forms for pour of the fountain walls and floor.
4. Steel Work – Lay out of rebar for fountain walls and floor.
5. Plumbing – Installation of hydraulic system including embed items and all piping and conduit between the fountain and equipment vault.
6. Install Equipment – Installation of equipment vault and excavation as needed. Based on maximum distance of 50' between fountain and vault.
7. Shell Structure – Form and pour fountain structure. Walls to be 10" thick, floor 6" thick.
8. Coping – Top of wall finish to be precast concrete, 14" wide, 2" thick, double bull nose.
9. Waterline Tile – Installation of single row of standard 6" waterline tile on the interior fountain wall.
10. Interior pool finish – Installation and materials for an exposed aggregate finish on all surfaces below the waterline tile.
11. Exterior wall finish – Apply stucco and paint, color TBD.
12. Electrical – We will provide installation and permitting of electrical components within fountain system. Does not include bringing power to the equipment vaults.
13. Final Equipment – We will install all final trim, nozzles, fittings and fixtures as required for a complete operational fountain system.
14. Start Up – We will provide a complete system start up. Fountain to be filled with water, started, and all final adjustments made for proper operation.

15. Turnover – We will provide a final walk through of the fountain in operation including an instructional training seminar for the owner. Site personnel will be instructed in the proper care and maintenance of the fountain, pumps and controls.
16. Operation & Maintenance Manual, As-built plans – We will provide an O & M manual and (3) sets of as-built plans.

Price

Hazeltine Nurseries, Inc.'s total, turnkey price to provide a complete, operational fountain system, including as-built construction plans, submittals, permits, sales tax and freight is as follows:

1. Equipment: vault, fixtures and fittings for (1) fountain - \$25,216
2. Installation: labor, materials, taxes, permits for (1) fountain - \$18,998
3. Total for one fountain - \$44,214

Total Price for (2) Fountains - \$88,428

Please call me to discuss after you review this proposal. I will be glad to price another option if this price is above the budget. Options that will further reduce the cost include:

- Reduce the display by using smaller or fewer nozzles
- Reduce the pump motor size to match the reduced display
- Eliminate the filter pump and use the same pump for the display and filtration. The disadvantage is that the water will be filtered only when the fountain is operating. The fountain water may not stay clean if the fountain is only allowed to operate a few hours a day.

I look forward to discussing this with you.

Very truly yours,

Myriam Murphy, P.E.
 PE # 42671, CPC # 1457291
 Tel: (941) 485-1272 x 138
 Email: mmurphy@hazeltinenurseries.com

RECORDED IN OFFICIAL RECORDS
INSTRUMENT # 2010081168 1 PG
2010 JUL 02 10:00 AM
KAREN E. RUSHING
CLERK OF THE CIRCUIT COURT
SARASOTA COUNTY, FLORIDA
FMILLER Receipt#1292552

This instrument prepared by and return to:

Mark C. Hanewich, Esq.
Nelson-Hesse, LLP, Attorneys at Law
2070 Ringling Boulevard
Sarasota, Florida 34237

Property Identification Number: 1116-01-0433

Doc Stamp-Deed: 0.70



QUITCLAIM DEED

THIS QUITCLAIM DEED, made and executed this _____ day of June, 2010, by the **NORTH PORT FIRE RESCUE DISTRICT**, a dependant special district of the **CITY OF NORTH PORT**, a political subdivision of the State of Florida, of 4970 City Hall Boulevard, North Port, Sarasota County, Florida 34286, hereinafter called the "Grantor", and **LAKESIDE PLANTATION COMMUNITY DEVELOPMENT DISTRICT**, a political subdivision of the State of Florida, of 2200 Plantation Boulevard, North Port, Sarasota County, Florida 34289, hereinafter called the "Grantee":

WITNESSETH:

That Grantor, for and in consideration of the sum of TEN and 00/100 (\$10.00) DOLLARS, and other good and valuable consideration to Grantor in hand paid by Grantee, receipt whereof is hereby acknowledged, does hereby grant, bargain, and quitclaim unto Grantee, all of Grantor's right, title, and interest in and to the following described real property lying and being situated in Sarasota County, Florida, *to-wit*:

Tract A-2, LAKESIDE PLANTATION, a subdivision according to the Plat thereof recorded in Plat Book 41, Pages 17, 17A through 17I, of the Public Records of Sarasota County, Florida.

Subject to restrictions, reservations and easements of record, if any, but this provision shall not operate to reimpose same, and taxes subsequent to the year 2009.

TOGETHER with all and singular the appurtenances thereunto belonging or in anywise appertaining, and all the estate, right, title, interest, lien, equity, and claim whatsoever of Grantor, either in law or equity, for the use, benefit, and profit of Grantee forever.

IN WITNESS WHEREOF, said Grantor has caused this instrument to be executed in its name by its duly authorized officer, the day and year first above written.

Signed, sealed and delivered in presence of:

NORTH PORT FIRE RESCUE DISTRICT,
a dependant special district of the
CITY OF NORTH PORT,
a political subdivision of the State of Florida

Patricia A. Edwards
Print Name: Patricia A. Edwards

By: [Signature]
DAVID GAROFALO, Chairman,
City Commission of the City of North Port

Ida Strong
Print Name: Ida Strong

STATE OF FLORIDA
COUNTY OF SARASOTA

The foregoing was acknowledged before me this 28th day of June 2010, by David Garofalo, Chairman, City Commission of the City of North Port, a political subdivision of the State of Florida, who is personally known to me; or produced a driver's license issued by the Florida Department of Motor Vehicles as identification; or produced the following identification: _____

Signature: Helen M. Raimbeau
NOTARY PUBLIC, State of Florida at Large
Typed name: Helen RAIMBEAU
My Commission Expires: _____
My Commission No.: _____

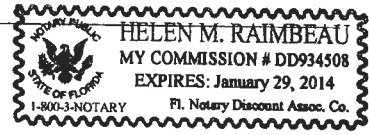

Lakeside Plantation Community Development District

Financial Statements
(Unaudited)

Period Ending
July 31, 2010



DMS

District Management Services, LLC

District Management Services, LLC
2002 North Lois Avenue ~ Suite 507 ~ Tampa, Florida 33607-2393
Phone (813) 873-7300 ~ Fax (813) 873-7070

Lakeside Plantation Community Development District

Balance Sheet

As of 7/31/2010

(In Whole Numbers)

	General Fund	Debt Service Fund	General Fixed Assets Account Group	General Long-Term Debt Account Group	TOTAL
Assets					
Cash	4,585	0	0	0	4,585
Investments--Current	467,441	90,563	0	0	558,004
Prepaid Items	8,165	0	0	0	8,165
Due From Other Funds	0	2	0	0	2
Amount Available In Debt Service Fund	0	0	0	90,565	90,565
Amount To Be Provided Debt Service	0	0	0	1,914,435	1,914,435
Fixed Assets	0	0	7,606,752	0	7,606,752
Total Assets	480,191	90,565	7,606,752	2,005,000	10,182,508
Liabilities					
Accounts Payable	15,504	0	0	0	15,504
Accrued Expenses Payable	716	0	0	0	716
Due To Other Funds	2	0	0	0	2
Revenue Bonds Payable--Long Term	0	0	0	2,005,000	2,005,000
Total Liabilities	16,223	0	0	2,005,000	2,021,223
Fund Equity & Other Credits Contributed Capital					
Investment In General Fixed Assets	0	0	7,606,752	0	7,606,752
Fund Balance--Reserved	0	86,681	0	0	86,681
Fund Balance--Unreserved	310,323	0	0	0	310,323
Net Changes In Fund Balances For Year	153,646	3,884	0	0	157,530
Total Fund Equity & Other Credits Contributed Capital	463,969	90,565	7,606,752	0	8,161,286
Total Liabilities & Fund Equity	480,191	90,565	7,606,752	2,005,000	10,182,508

Lakeside Plantation Community Development District

Income Stmt - GF

General Fund - 001

From 10/1/2009 Through 7/31/2010

(In Whole Numbers)

	Annual Budget	Current Period Actual	Budget to Actual Variance	Budget Percent Remaining
Revenues				
Special Assessments - Service Charges				
Operations & Maintenance Assmts-Tax Roll	651,844	657,471	5,627	0.86%
Total Special Assessments - Service Charges	651,844	657,471	5,627	0.86%
Interest Earnings				
Interest Earnings	2,000	1,663	(337)	(16.85)%
Total Interest Earnings	2,000	1,663	(337)	(16.85)%
Other Miscellaneous Revenues				
Miscellaneous	0	3,572	3,572	0.00%
Clubhouse Rentals	3,000	2,293	(707)	(23.55)%
Activities	7,000	7,544	544	7.77%
Tennis Club	15,000	13,323	(1,677)	(11.17)%
Total Other Miscellaneous Revenues	25,000	26,733	1,733	6.93%
Total Revenues	678,844	685,867	7,023	1.03%
Expenditures				
Legislative				
Supervisor Fees	9,000	9,400	(400)	(4.44)%
Payroll Taxes	700	306	394	56.28%
Total Legislative	9,700	9,706	(6)	(0.06)%
Financial & Administrative				
District Manager	46,500	38,725	7,775	16.72%
District Engineer	7,000	820	6,180	88.28%
Disclosure Report	0	1,000	(1,000)	0.00%
Trustees Fees	0	701	(701)	0.00%
Assessment Roll	5,000	1,250	3,750	75.00%
Audit Fees	8,300	8,000	300	3.61%
Public Communications	250	40	210	84.00%
General Liability Insurance	6,000	4,015	1,986	33.09%
Postage	900	253	647	71.94%
Printing & Binding	1,000	431	569	56.86%
Legal Advertising	1,500	286	1,214	80.96%
Dues, Licenses & Fees	175	175	0	0.00%
Other Current Charges	2,200	1,460	740	33.61%
Total Financial & Administrative	78,825	57,156	21,669	27.49%
Legal Counsel				
District Counsel	12,000	21,283	(9,283)	(77.36)%
Total Legal Counsel	12,000	21,283	(9,283)	(77.36)%

Lakeside Plantation Community Development District

Income Stmt - GF

General Fund - 001

From 10/1/2009 Through 7/31/2010

(In Whole Numbers)

	Annual Budget	Current Period Actual	Budget to Actual Variance	Budget Percent Remaining
General Maintenance				
Personnel Services	115,000	136,637	(21,637)	(18.81)%
Payroll Taxes	8,798	9,806	(1,008)	(11.45)%
Health Insurance	10,000	4,113	5,887	58.86%
Workers' Comp Insurance	4,000	2,678	1,322	33.05%
Temp Services	5,000	164	4,836	96.72%
Travel Reimbursement	1,800	561	1,239	68.83%
Roadway Maintenance	10,000	16,593	(6,593)	(65.93)%
Common Area Maintenance	9,000	5,911	3,089	34.32%
Common Area Renewal & Replacement	1,000	0	1,000	100.00%
Street Lighting	6,000	3,258	2,742	45.70%
Lawn Service/Landscaping-Contractual	76,941	61,500	15,441	20.06%
Plant Replacement Program	7,016	930	6,086	86.74%
Irrigation Maintenance	2,500	1,052	1,448	57.93%
Lake Maintenance	11,742	8,660	3,082	26.24%
Lake Bank Restoration	10,000	0	10,000	100.00%
Entrance Feature - Electric	8,500	5,169	3,331	39.19%
Entrance Feature-Utilities/Water	6,000	5,645	355	5.91%
Entrance Feature - Repairs/Maint.	6,000	2,844	3,156	52.60%
Misc. Tools, Equipment & Supplies	2,500	2,290	210	8.39%
Total General Maintenance	301,797	267,810	33,987	11.26%
Clubhouse/Pool/Tennis Courts				
Clubhouse - Activities	19,000	15,514	3,486	18.34%
Clubhouse - General Supplies	1,775	3,226	(1,451)	(81.76)%
Clubhouse - Maintenance	6,000	6,380	(380)	(6.33)%
Clubhouse - Renewal & Replacements	5,000	8,449	(3,449)	(68.98)%
Clubhouse - Office Supplies	2,000	2,317	(317)	(15.86)%
Clubhouse - Pest Control	750	750	0	0.00%
Clubhouse - Security	2,000	7,346	(5,346)	(267.28)%
Clubhouse - AED	5,000	2,430	2,570	51.40%
Clubhouse - Telephone & Internet	3,000	2,793	207	6.91%
Clubhouse - Exercise Equipment	11,092	7,170	3,922	35.35%
Clubhouse - Furniture	2,000	0	2,000	100.00%
Clubhouse - Janitorial Supplies	1,600	1,262	338	21.13%
Clubhouse/Tennis - Electric	9,000	9,298	(298)	(3.31)%
Clubhouse - Gas	150	132	18	11.78%
Club/Pool - Waste Removal/Refuse	2,000	1,035	965	48.25%
Clubhouse/Pool - Water & Sewer	2,000	1,795	205	10.24%

Lakeside Plantation Community Development District

Income Stmt - GF

General Fund - 001

From 10/1/2009 Through 7/31/2010

(In Whole Numbers)

	Annual Budget	Current Period Actual	Budget to Actual Variance	Budget Percent Remaining
Pool - Electric	20,000	14,726	5,274	26.37%
Pool - Furniture	2,400	2,943	(543)	(22.62)%
Pool - Maintenance	7,000	7,806	(806)	(11.50)%
Tennis Court - Maintenance	3,500	3,009	491	14.01%
Tennis Court - Programs	3,000	2,492	508	16.93%
Tennis Court - Water	3,000	6,002	(3,002)	(100.07)%
Total Clubhouse/Pool/Tennis Courts	<u>111,267</u>	<u>106,875</u>	<u>4,392</u>	<u>3.95%</u>
Other Expenses				
Contingencies	84,285	10,000	74,285	88.13%
Property Taxes	45,000	42,275	2,725	6.05%
Property Insurance	15,000	6,579	8,421	56.14%
Permit Fees	600	675	(75)	(12.50)%
Property Appraiser Fees	10,185	0	10,185	100.00%
Tax Collector Fees	10,185	9,862	323	3.17%
Total Other Expenses	<u>165,255</u>	<u>69,391</u>	<u>95,864</u>	<u>58.01%</u>
Total Expenditures	<u>678,844</u>	<u>532,221</u>	<u>146,623</u>	<u>21.60%</u>
Subtotal: Rev Over / (Under) Exp	0	153,646	153,646	0.00%
Total: Revenues Over / Under Expenditures	<u>0</u>	<u>153,646</u>	<u>153,646</u>	<u>0.00%</u>

Lakeside Plantation Community Development District

Statement of Revenues and Expenditures

Debt Service Fund - 200

From 10/1/2009 Through 7/31/2010

(In Whole Numbers)

	Annual Budget	Current Period Actual	Budget to Actual Variance	Budget Percent Remaining
Revenues				
Special Assessments - Capital Improvements				
Debt Service Assmts-Tax Roll	187,186	188,804	1,618	0.86%
Interest Earnings				
Interest Earnings	0	40	40	0.00%
Total Revenues	<u>187,186</u>	<u>188,844</u>	<u>1,658</u>	<u>0.89%</u>
Expenditures				
Debt Service Payments				
Interest Payments	142,128	142,128	1	0.00%
Principal Payments	45,000	40,000	5,000	11.11%
Other Expenses				
Tax Collector Fees	2,924	2,832	92	3.14%
Total Expenditures	<u>190,052</u>	<u>184,960</u>	<u>5,092</u>	<u>2.68%</u>
Excess of Revenues Over (Under) Expenditures	<u>(2,866)</u>	<u>3,884</u>	<u>6,750</u>	<u>(235.52)%</u>
Exc of Rev./Other Sources Over Expend./Other Uses	<u>(2,866)</u>	<u>3,884</u>	<u>6,750</u>	<u>(235.52)%</u>

Lakeside Plantation Community Development District
Reconcile Cash Accounts

Reconciliation Date: 7/31/2010
Cash Account: 10101 Cash-BB&T Operating A/C

Bank Balance	4,139.01
Less Outstanding Checks/Vouchers	1,301.88
Plus Deposits in Transit	0.00
Plus or Minus Other Cash Items	0.00
Plus or Minus Suspense Items	<u>0.00</u>
Reconciled Bank Balance	2,837.13
Balance Per Books	<u>2,837.13</u>
Unreconciled Difference	<u><u>0.00</u></u>

Lakeside Plantation Community Development District
Reconcile Cash Accounts
Outstanding Checks/Vouchers

Reconciliation Date: 7/31/2010

Cash Account: 10101 Cash-BB&T Operating A/C

<u>Document Number</u>	<u>Document Date</u>	<u>Document Description</u>	<u>Document Amount</u>	<u>Payee</u>
1726	3/11/2010	System Generated Check/Voucher	200.00	David Polk
1810	5/15/2010	System Generated Check/Voucher	50.00	Mike Stewart
1878	6/25/2010	System Generated Check/Voucher	400.00	David Polk
1919	7/23/2010	System Generated Check/Voucher	305.00	BMI
1922	7/23/2010	System Generated Check/Voucher	244.20	Culligan Water Conditioning of Nokomis
1924	7/23/2010	System Generated Check/Voucher	102.68	Richard Terpstra
Outstanding Checks/Vouchers			<u>1,301.88</u>	



864-02-01-00 50368 53 C 001 29 55 004
LAKESIDE PLANTATION CDD
2002 N LOIS AVE STE 507
TAMPA FL 33607-2393

Your consolidated statement

For 07/30/2010

Contact us



BBT.com



(800) BANK-BBT or
(800) 226-5228

Improve your cash flow with next-day funding!

If you are accepting credit and debit cards today, but are not processing through BB&T Merchant Services, you may be missing out on having access to your funds sooner.

By choosing BB&T Merchant Services, we'll:

- Match or beat your current processing costs, or give you a great low rate if you are not already accepting cards*
- Support credit and debit card processing for all major card types - Visa®, MasterCard®, Discover® Network, and American Express®
- Provide free web-based reporting
- Reprogram your existing equipment for free

-- All with next-day funding with your BB&T Business Checking Account.

To find out more visit www.BBT.com/merchantservices or for a free quote, call BB&T Merchant Services at 1-800-226-5228.

*Subject to business type and credit approval. Offer valid for clients with Visa/MasterCard/Discover Network aggregate annual sales less than \$2.5 million. Offer not available to existing merchant services clients.

BB&T Merchant Services are provided by BB&T Financial, FSB, a subsidiary of BB&T Corporation. Member FDIC.

©2010, Branch Banking and Trust Company. All Rights Reserved. Member FDIC.

Summary of your accounts

ACCOUNT NAME	ACCOUNT NUMBER	BALANCE(\$)	DETAILS ON
BASIC PUBLIC FUND CHECKING		4,139.01	page 1
PUBLIC FUND MONEY RATE SAVINGS		467,048.13	page 2
Total checking and money market savings accounts		\$471,187.14	



Checking and money market savings accounts

■ BASIC PUBLIC FUND CHECKING

____ Former Account Number ^^^

Account summary

Your previous balance as of 06/30/2010	\$50,979.92
Checks	- 77,339.41
Other withdrawals, debits and service charges	- 0.00
Deposits, credits and interest	+ 30,498.50
Your new balance as of 07/30/2010	= \$4,139.01

■ BASIC PUBLIC FUND CHECKING

____ Former Account Number (

Checks

DATE	CHECK #	AMOUNT(\$)	DATE	CHECK #	AMOUNT(\$)	DATE	CHECK #	AMOUNT(\$)
07/01	1865	400.00	07/01	1887	9,816.67	07/19	1907	90.00
07/06	1866	400.00	07/02	1888	512.98	07/15	1908	200.00
07/02	1867	400.00	07/01	1889	950.93	07/20	1909	654.47
07/01	1868	400.00	07/02	1890	1,165.56	07/27	1910	1,955.45
07/01	1869	6.95	07/02	1891	750.00	07/19	1911	343.20
07/06	1870	273.31	07/01	1892	180.16	07/20	1912	866.00
07/01	1871	498.50	07/06	1893	471.93	07/20	1913	146.00
07/01	1872	100.66	07/14	1894	352.74	07/19	1914	390.39
07/01	1873	3,178.25	07/16	1895	152.50	07/20	1915	379.57
07/06	1874	128.25	07/13	1896	157.98	07/20	1916	143.00
07/02	1875	116.50	07/13	1897	860.71	07/21	1917	3,618.00
07/06	1876	11,107.70	07/13	1898	759.28	07/30	1918	183.15
07/06	*1880	417.29	07/09	*1900	1,263.88	07/30	*1920	400.00
07/07	1881	16,593.00	07/09	*1902	180.00	07/30	*1921	273.73
07/01	1882	340.00	07/12	1903	6,100.00	07/30	*1923	182.90
07/02	1883	12.77	07/15	1904	6,025.00	07/28	*1925	170.00
07/01	*1885	69.55	07/20	1905	675.00	07/29	1926	90.00
07/06	1886	2,285.50	07/19	1906	150.00			

* indicates a skip in sequential check numbers above this item

Total checks = \$77,339.41

Deposits, credits and interest

DATE	DESCRIPTION	AMOUNT(\$)
07/02	BB&T ONLINE TRANSFER TRANSFER FROM CHECKING	6,000.00
07/08	BB&T ONLINE TRANSFER TRANSFER FROM CHECKING	16,000.00
07/16	BB&T ONLINE TRANSFER TRANSFER FROM CHECKING	8,000.00
07/16	DEPOSIT	377.00
07/26	DEPOSIT	121.50

Total deposits, credits and interest = \$30,498.50

BB&T Investment Acct
000000#0543
July 31, 2010

Previous Balance:	06/30/10	\$	496,896.42
Credits:			
	Tax Collector		10.62
	Interest		<u>141.09</u>
Total Deposits:			<u>151.71</u>
Debits:	Transfer to Operating Account		(30,000.00)
			<u>(30,000.00)</u>
Total Debits			<u>(30,000.00)</u>
Ending Bank Balance	07/31/10	\$	<u>467,048.13</u>

Account summary

Your previous balance as of 06/30/2010	\$496,896.42
Checks	- 0.00
Other withdrawals, debits and service charges	- 30,000.00
Deposits, credits and interest	+ 151.71
Your new balance as of 07/30/2010	= \$467,048.13

Interest summary

Interest paid this statement period	\$141.09
2010 interest paid year-to-date	\$1,082.72
Interest rate	0.35%
Annual percentage yield (APY) earned	0.35%

Other withdrawals, debits and service charges

DATE	DESCRIPTION	AMOUNT(\$)
07/02	BB&T ONLINE TRANSFER TRANSFER TO CHECKING	6,000.00
07/08	BB&T ONLINE TRANSFER TRANSFER TO CHECKING	16,000.00
07/16	BB&T ONLINE TRANSFER TRANSFER TO CHECKING	8,000.00
Total other withdrawals, debits and service charges		= \$30,000.00

Deposits, credits and interest

DATE	DESCRIPTION	AMOUNT(\$)
07/30	TAX DIST SARASOTA CO TAX LAKESIDE PLANTATION	10.62
07/30	EFFECTIVE DATE 7-31-10 INTEREST PAYMENT	141.09
Total deposits, credits and interest		= \$151.71

Lakeside Plantation Community Development District
Reconcile Cash Accounts

Reconciliation Date: 7/31/2010
Cash Account: 10102 Cash-BB&T Activities A/C

Bank Balance	1,548.12
Less Outstanding Checks/Vouchers	0.00
Plus Deposits in Transit	0.00
Plus or Minus Other Cash Items	0.00
Plus or Minus Suspense Items	<u>0.00</u>
Reconciled Bank Balance	1,548.12
Balance Per Books	<u>1,548.12</u>
Unreconciled Difference	<u><u>0.00</u></u>



864-02-01-00 50368 10 C 001 29 55 004
LAKESIDE PLANTATION CDD
ACTIVITIES ACCT
2002 N LOIS AVE STE 507
TAMPA FL 33607-2393

Your account statement

For 07/30/2010

Contact us



BBT.com



(800) BANK-BBT or
(800) 226-5228

Improve your cash flow with next-day funding!

If you are accepting credit and debit cards today, but are not processing through BB&T Merchant Services, you may be missing out on having access to your funds sooner.

By choosing BB&T Merchant Services, we'll:

- Match or beat your current processing costs, or give you a great low rate if you are not already accepting cards*
- Support credit and debit card processing for all major card types - Visa®, MasterCard®, Discover® Network, and American Express®
- Provide free web-based reporting
- Reprogram your existing equipment for free

-- All with next-day funding with your BB&T Business Checking Account.

To find out more visit www.BBT.com/merchantservices or for a free quote, call BB&T Merchant Services at 1-800-226-5228.

*Subject to business type and credit approval. Offer valid for clients with Visa/MasterCard/Discover Network aggregate annual sales less than \$2.5 million. Offer not available to existing merchant services clients.

BB&T Merchant Services are provided by BB&T Financial, FSB, a subsidiary of BB&T Corporation. Member FDIC.
©2010, Branch Banking and Trust Company. All Rights Reserved. Member FDIC.

■ BASIC PUBLIC FUND CHECKING

___ Former Account Number

Account summary

Your previous balance as of 06/30/2010	\$2,080.79
Checks	- 605.67
Other withdrawals, debits and service charges	- 0.00
Deposits, credits and interest	+ 73.00
Your new balance as of 07/30/2010	= \$1,548.12

Checks

DATE	CHECK #	AMOUNT(\$)
07/02	2068	69.95
07/22	2069	9.31
07/07	2070	29.01
07/08	2071	50.00

DATE	CHECK #	AMOUNT(\$)
07/12	2072	40.00
07/09	2073	7.14
07/19	2074	140.00

DATE	CHECK #	AMOUNT(\$)
07/20	2075	150.00
07/21	2076	13.91
07/26	2077	96.35

Total checks = \$605.67

Deposits, credits and interest

DATE	DESCRIPTION	AMOUNT(\$)
07/26	DEPOSIT	73.00
Total deposits, credits and interest		= \$73.00



State Board of Administration
LOCAL GOVERNMENT SURPLUS TRUST FUNDS INVESTMENT POOL
PARTICIPANT STATEMENT OF ACCOUNT
FROM 7/1/2010 TO 7/31/2010
LGIP
 (formerly known as LGIP-A)
AGENCY ACCOUNT

LAKESIDE PLANTATION
 COMMUNITY DEVELOPMENT DISTRICT
 2002 N LOIS AVE STE 507
 TAMPA, FL 33607

Participant Return: 0.38 %

Date	Transaction Type	Description	Amount	Balance
7/1/2010	BEGINNING BALANCE			87.07
7/8/2010	TRANSFER IN	RETURN OF FUNDS FROM LGIP B	6.10	93.17
7/31/2010	EARNED INCOME	INTEREST	0.03	93.20
Totals:			6.13	93.20

002

93.20+
 299.93+
 393.13*

Fund B statements will be mailed separately by mid-month.

For questions regarding your statement, please call (850) 488-7311 or Suncom # 278-7311

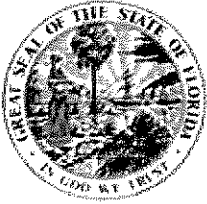

State Board of Administration
LOCAL GOVERNMENT SURPLUS TRUST FUNDS INVESTMENT POOL
PARTICIPANT STATEMENT OF ACCOUNT
FROM 7/1/2009 TO 6/30/2010
FUND B
 (formerly known as LGIP-B)
AGENCY ACCOUNT

LAKESIDE PLANTATION
 COMMUNITY DEVELOPMENT DISTRICT
 2002 N LOIS AVE STE 507
 TAMPA, FL 33607

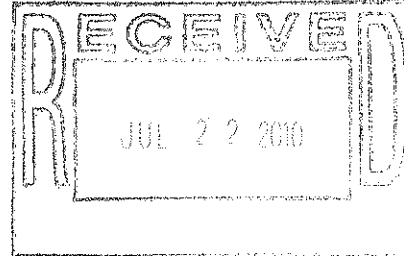

Date	Transaction Type	Description	Amount	Balance
7/1/2009	BEGINNING BALANCE			394.55
7/8/2009	TRANSFER OUT	DISTRIBUTION TO LGIP	(5.14)	389.41
8/6/2009	TRANSFER OUT	DISTRIBUTION TO LGIP	(5.90)	383.51
9/4/2009	TRANSFER OUT	DISTRIBUTION TO LGIP	(7.24)	376.27
10/6/2009	TRANSFER OUT	DISTRIBUTION TO LGIP	(5.83)	370.44
11/5/2009	TRANSFER OUT	DISTRIBUTION TO LGIP	(4.89)	365.55
12/7/2009	TRANSFER OUT	DISTRIBUTION TO LGIP	(4.53)	361.02
1/7/2010	TRANSFER OUT	DISTRIBUTION TO LGIP	(25.20)	335.82
2/5/2010	TRANSFER OUT	DISTRIBUTION TO LGIP	(6.21)	329.61
3/5/2010	TRANSFER OUT	DISTRIBUTION TO LGIP	(4.42)	325.19
4/7/2010	TRANSFER OUT	DISTRIBUTION TO LGIP	(4.02)	321.17
5/6/2010	TRANSFER OUT	DISTRIBUTION TO LGIP	(5.20)	315.97
6/4/2010	TRANSFER OUT	DISTRIBUTION TO LGIP	(9.94)	306.03
6/30/2010	PRINCIPAL BALANCE		<u>(88.52)</u>	<u>306.03</u>

% of Ownership:	0.00007243%	7/8/10 TRANSFER OUT	<6-107	299.93
Ending NAV Balance: *	206.12			
Unrealized Gain (Loss):	(99.91)			

DISCLOSURE

Total NAV Fund B:	284,585,199.53
Reserve Account:	0.00
Total NAV for Participants:	<u>284,585,199.53</u>

* Ending NAV Balance represents your share of the Fund B NAV available for participants.
 For further information regarding the Reserve Account, please reference our website.

Lakeside Plantation
 Community Development Districts
 Special Assessment Receipts
 Fiscal Year Ending September 30, 2010

DATE RECEIVED	GROSS ASSESSMENTS RECEIVED	COMMISSIONS	PENALTIES / DISCOUNTS	INTEREST	NET AMOUNT RECEIVED	GENERAL	1999 DEBT SERVICE	DEBT SERVICE	TOTAL	TOTAL BUDGETED AMOUNTS		
										77.69%	22.31%	0.00%
11/18/09	\$57,593.68	\$827.43	\$2,431.51	\$0.00	\$54,334.74	\$42,212.66	\$12,122.08	\$0.00	\$54,334.74			
11/30/09	\$176,802.48	\$2,574.76	\$7,152.04	\$0.00	\$169,075.68	\$131,354.90	\$37,720.78	\$0.00	\$169,075.68			
12/14/09	\$333,141.63	\$4,797.35	\$13,318.41	\$0.00	\$315,025.87	\$244,743.60	\$70,282.27	\$0.00	\$315,025.87			
12/30/09	\$55,339.14	\$797.14	\$2,196.22	\$0.00	\$52,345.78	\$40,667.44	\$11,678.34	\$0.00	\$52,345.78			
01/29/10	\$25,131.23	\$365.49	\$765.45	\$139.63	\$24,139.92	\$18,754.30	\$5,385.62	\$0.00	\$24,139.92			
02/12/10	\$15,656.57	\$229.45	\$360.03	\$0.00	\$15,067.09	\$11,705.62	\$3,361.47	\$0.00	\$15,067.09			
03/31/10	\$43,320.02	\$649.80	\$0.00	\$0.00	\$42,670.22	\$33,150.49	\$9,519.73	\$0.00	\$42,670.22			
04/23/10	\$103,981.32	\$1,559.72	\$0.00	\$28.01	\$102,449.61	\$79,593.10	\$22,856.51	\$0.00	\$102,449.61			
05/21/10	\$8,986.75	\$134.80	\$0.00	\$0.00	\$8,851.95	\$6,877.08	\$1,974.87	\$0.00	\$8,851.95			
06/04/10	\$48,410.04	\$758.19	(\$2,136.15)	\$0.00	\$48,788.00	\$38,660.30	\$11,107.70	\$0.00	\$48,788.00			
07/30/10	\$0.00	\$0.00	\$0.00	\$10.62	\$10.62	\$8.25	\$2.37	\$0.00	\$10.62			
10/12/09	\$0.00	\$0.00	\$0.00	\$0.00	\$0.00	\$0.00	\$0.00	\$0.00	\$0.00			
10/13/09	\$0.00	\$0.00	\$0.00	\$0.00	\$0.00	\$0.00	\$0.00	\$0.00	\$0.00			
10/14/09	\$0.00	\$0.00	\$0.00	\$0.00	\$0.00	\$0.00	\$0.00	\$0.00	\$0.00			
10/15/09	\$0.00	\$0.00	\$0.00	\$0.00	\$0.00	\$0.00	\$0.00	\$0.00	\$0.00			
10/16/09	\$0.00	\$0.00	\$0.00	\$0.00	\$0.00	\$0.00	\$0.00	\$0.00	\$0.00			
TOTALS	\$870,362.86	\$12,694.13	\$24,087.51	\$178.26	\$833,759.48	\$647,747.74	\$186,011.74	\$0.00	\$833,759.48			

GF \$9,862.07
 DS \$2,832.06
 Total \$138.49
 \$39.77

Description	General	Debt Service - 201	Debt Service	Total
Gross Levy	\$679,004.15	\$194,984.86	\$0.00	\$873,989.01
Discounts	\$0.00	\$0.00	\$0.00	\$0.00
Property Appraise	\$0.00	\$0.00	\$0.00	\$0.00
Tax Collector	\$0.00	\$0.00	\$0.00	\$0.00
Net Collections:	\$679,004.15	\$194,984.86	\$0.00	\$873,989.01
Dist Percent	77.69%	22.31%	0.00%	100.00%
General Fund	\$657,471.32			
Debt Service	\$188,804.03			

Collection Percentage 99.59%

D/S Transfers	Date	Amount
	03/22/10	140,550.56
	04/05/10	9,519.73
	05/15/10	23,198.23
	05/26/10	1,633.15
	06/25/10	11,107.70
	07/30/10	

Total Transferred \$186,009.37
 Total Remaining \$2.37

BOND DEBT SERVICE

Lakeside Plantation Community Development District
Capital Improvement Revenue Bonds, Series 1999A

Period Ending	Principal	Coupon	Interest	Debt Service	Annual Debt Service
11/01/2008			72,453.75	72,453.75	72,453.75
05/01/2009	40,000	6.950%	72,453.75	112,453.75	
11/01/2009			71,063.75	71,063.75	183,517.50
05/01/2010	40,000	6.950%	71,063.75	111,063.75	
11/01/2010			69,673.75	69,673.75	180,737.50
05/01/2011	45,000	6.950%	69,673.75	114,673.75	
11/01/2011			68,110.00	68,110.00	182,783.75
05/01/2012	45,000	6.950%	68,110.00	113,110.00	
11/01/2012			66,546.25	66,546.25	179,656.25
05/01/2013	50,000	6.950%	66,546.25	116,546.25	
11/01/2013			64,808.75	64,808.75	181,355.00
05/01/2014	55,000	6.950%	64,808.75	119,808.75	
11/01/2014			62,897.50	62,897.50	182,706.25
05/01/2015	60,000	6.950%	62,897.50	122,897.50	
11/01/2015			60,812.50	60,812.50	183,710.00
05/01/2016	60,000	6.950%	60,812.50	120,812.50	
11/01/2016			58,727.50	58,727.50	179,540.00
05/01/2017	65,000	6.950%	58,727.50	123,727.50	
11/01/2017			56,468.75	56,468.75	180,196.25
05/01/2018	70,000	6.950%	56,468.75	126,468.75	
11/01/2018			54,036.25	54,036.25	180,505.00
05/01/2019	75,000	6.950%	54,036.25	129,036.25	
11/01/2019			51,430.00	51,430.00	180,466.25
05/01/2020	80,000	6.950%	51,430.00	131,430.00	
11/01/2020			48,650.00	48,650.00	180,080.00
05/01/2021	85,000	6.950%	48,650.00	133,650.00	
11/01/2021			45,696.25	45,696.25	179,346.25
05/01/2022	95,000	6.950%	45,696.25	140,696.25	
11/01/2022			42,395.00	42,395.00	183,091.25
05/01/2023	100,000	6.950%	42,395.00	142,395.00	
11/01/2023			38,920.00	38,920.00	181,315.00
05/01/2024	110,000	6.950%	38,920.00	148,920.00	
11/01/2024			35,097.50	35,097.50	184,017.50
05/01/2025	115,000	6.950%	35,097.50	150,097.50	
11/01/2025			31,101.25	31,101.25	181,198.75
05/01/2026	125,000	6.950%	31,101.25	156,101.25	
11/01/2026			26,757.50	26,757.50	182,858.75
05/01/2027	135,000	6.950%	26,757.50	161,757.50	
11/01/2027			22,066.25	22,066.25	183,823.75
05/01/2028	140,000	6.950%	22,066.25	162,066.25	
11/01/2028			17,201.25	17,201.25	179,267.50
05/01/2029	155,000	6.950%	17,201.25	172,201.25	
11/01/2029			11,815.00	11,815.00	184,016.25
05/01/2030	165,000	6.950%	11,815.00	176,815.00	
11/01/2030			6,081.25	6,081.25	182,896.25
05/01/2031	175,000	6.950%	6,081.25	181,081.25	
11/01/2031					181,081.25
	2,085,000		2,165,620.00	4,250,620.00	4,250,620.00

Lakeside Plantation Community Development District

Check/Voucher Register - Check Register Diane - Activities

10102 - Cash-BB&T Activities A/C

From 7/1/2010 Through 7/31/2010

Check ...	Check Date	Vendor Name	Transaction Description	Check Amount
2068	7/1/2010	Sandy Bock	Wine & Cheese Reim	69.95
2069	7/1/2010	Diane Picataggio	Bread & Cheese Italian Pot Luck	9.31
2070	7/5/2010	Publix	Food for American Celb	29.01
2071	7/5/2010	Jay Hampton	Face Painting -American Celebration	50.00
2072	7/7/2010	Do All Rental	Sno Kone Machine American Cel-Rental	40.00
2073	7/7/2010	Publix	Waffle Mix & Eggs-Ice Cream Social	7.14
2074	7/17/2010	Laura West	Pizza Purchase Little Caesars-Family Swim Nite	140.00
2075	7/17/2010	Musk Entertainment	Musk Entertainment-Family Swim Party	150.00
2076	7/17/2010	Dollar Tree	Family Swim	13.91
2077	7/23/2010	Bella Napoli	Pizza Bite	96.35
Report Total				605.67

Lakeside Plantation Community Development District

Check/Voucher Register - Check Register Diane

10101 - Cash-BB&T Operating A/C

From 7/1/2010 Through 7/31/2010

Ch...	Check D...	Vendor Name	Invoice Number	Transaction Description	Check Amount
1885	7/1/2010	Bob Babik	BB-Reim Exp	Repair to Bocce Ball Court - Machine Rental Reim	69.55
1886	7/1/2010	Clinton Casual	6883	Pool Deck Umbrella	152.50
	7/1/2010	Clinton Casual	6888	Repair to Pool Deck Umbrella	45.00
	7/1/2010	Clinton Casual	6913	Pool Deck Chairs 12	2,088.00
1887	7/1/2010	District Management S...	2220	July Management Services & Semi Monthly Staffing & Program A	9,816.67
1888	7/1/2010	Florida Power & Light C...	04126-05586 - 071510	Electric Service 05/25/10-06/24/10	512.98
1889	7/1/2010	Florida Power & Light C...	57421-67439 -071510	Electric Service 05/25/10-06/24/10	950.93
1890	7/1/2010	Florida Power & Light C...	84595-15071-071510	Electric Service 05/25/10-06/24/10	1,165.56
1891	7/1/2010	Kennedy Electric Co. of...	9948	Replaced 6 Lamps/electrician/6-175 w/lamp	750.00
1892	7/1/2010	Sparkle Brite Pool of N...	73835	Chlorine	27.32
	7/1/2010	Sparkle Brite Pool of N...	74107	Chlorine	24.56
	7/1/2010	Sparkle Brite Pool of N...	74705	Chlorine,Adj Brown Course Pad	32.98
	7/1/2010	Sparkle Brite Pool of N...	75277	Chlorine	27.46
	7/1/2010	Sparkle Brite Pool of N...	75278	Chlorine, Yellow Jack Stuff	40.24
	7/1/2010	Sparkle Brite Pool of N...	76454	Chlorine	27.60
1893	7/1/2010	Staples Credit Plan	6035 5178 7242 8692 - 061510	Office Supplies & HP Wireless Printer	471.93
1894	7/6/2010	William Capozzi	Employee Rick T Cell Phone 12/09-05/10	Remi for Employee Cell Phone Rick Terpstra-12/09-05/10	352.74
1895	7/6/2010	Clinton Casual	6939	1 Umbrella 906 Wedgewood Shade	152.50
1896	7/6/2010	North Port Solid Waste ...	43123-156052-062510	Water Services 05/20/10-06/18/10	157.98
1897	7/6/2010	North Port Utilities	43123-154656 - 062510	Water Services 05/20/10-06/18/10	860.71
1898	7/6/2010	North Port Utilities	43123-154658-062510	Water Services 05/20/10-06/18/10	759.28
1899	7/6/2010	New View, Inc.	46208	Pressure Wash Sidewalk around Clubhouse	0.00
1900	7/6/2010	Rubber Concepts, Inc.	2006007489-Equipt	Rental Equipment, Fuel & Labor for Deck Repairs	500.00
	7/6/2010	Rubber Concepts, Inc.	Final Payment-011810	Reseal & Patch Pool Deck Final Payment	763.88
1901	7/6/2010	Sarasota County Tax C...	58-60-01251 063010	2010 Renewal Swimming Pool /Bathing Permit 58-60-01251	0.00
1902	7/6/2010	Sarasota County Tax C...	58-60-01252 063010	2010 Renewal Swimming Pool/Bathing Permit 58-60-01252	0.00
1903	7/6/2010	Security Alarm Corp.	52323	Service Call to Premises & reset Breaker & Batteries	180.00
1904	7/6/2010	Teal Lawn	10709	Landscape Maint. July Services	6,100.00
1905	7/15/2010	District Management S...	2219	Semi Monthly Billing for Staff and Program Admin	6,025.00
1906	7/6/2010	Sarasota County Health...	586001251	Renewal of Swimming Pool / Spa Permit	400.00
1907	7/6/2010	Sarasota County Health...	586001256	Pool Permit # 58-60-1252	275.00
1908	7/14/2010	A-1 Superior Pest Contr...	121347	Pest Control July	150.00
1909	7/14/2010	Babe's Plumbing, Inc.	119718	Repaired Leaking Pipe in Men's Water Closet	90.00
1910	7/14/2010	District Management S...	2238	Contact Contact Web Service Feb thru June 10	200.00
	7/14/2010	Florida Department of ...	68-8015405857-0601	Sale & Use tax 68-8015405854-5	654.47
	7/14/2010	Gulf Carts of Port Charl...	44246	Full Service & Repairs to Gulf Cart	330.45

Lakeside Plantation Community Development District

Check/Voucher Register - Check Register Diane

10101 - Cash-BB&T Operating A/C

From 7/1/2010 Through 7/31/2010

Ch...	Check D...	Vendor Name	Invoice Number	Transaction Description	Check Amount
1911	7/14/2010	Gulf Carts of Port Charl...	8270	Purchase of New Gulf Cart	1,625.00
1912	7/14/2010	Home Depot Credit Ser...	6035 3225 0282 9538 -06/29/10	Supplies,Tape Pushbroom,Sealer	343.20
1913	7/14/2010	Lake Masters Aquatic ...	10-44787	Monthly Service-Treatment of Waterway & Canals July	866.00
1914	7/14/2010	North Port Solid Waste ...	54883-159826 - 070110	3 Auto Containers 5/31/10-06/30/10	146.00
		Sam's Club	7715 0901 1476 2388 - 06/27/2010	General Supplies Cups,Drinks,P.Towels.Fruit.Food	390.39
1915	7/14/2010	Sparkle Brite Pool of N...	76819	Chlorine, AAA De Filter Powder 8oz Sticks	196.40
	7/14/2010	Sparkle Brite Pool of N...	77563	Chlorine	17.25
	7/14/2010	Sparkle Brite Pool of N...	77715	Chlorine, VWP Adjustable Deluxe	36.90
	7/14/2010	Sparkle Brite Pool of N...	77716	Chlorine	10.35
	7/14/2010	Sparkle Brite Pool of N...	78139	Chlorine	26.77
	7/14/2010	Sparkle Brite Pool of N...	78580	Chlorine, AAA De Filter Powder	36.84
	7/14/2010	Sparkle Brite Pool of N...	79098	Chlorine	27.46
	7/14/2010	Sparkle Brite Pool of N...	79612	Chlorine	27.60
1916	7/14/2010	Stan Oley's Tennis Equi...	104293	Service Call Ball Machine & Oscillation Springs	143.00
1917	7/14/2010	US Bank	2655650	Trustee Fee 06/01/10-05/31/2011	3,618.00
1918	7/23/2010	Archer Janitorial & Pap...	1238-071410	Gym Wipes-Anitb.toweettes/refill & Urnial Screen W/Block	183.15
1919	7/23/2010	BMI	20031375	Esrimated Fee 07/01/10-06/30/11	305.00
1920	7/23/2010	Calico Tractor Mowing	23696	Mow at Lakeside 07/19/10	400.00
1921	7/23/2010	Comcast Communicatio...	15515999177-02-9 -07014	Phone & Internet 07/24-08/23/10	273.73
1922	7/23/2010	Culligan Water Conditio...	1017805-0614	Drinking Water,cone cups & Delivery Chrgre June	244.20
1923	7/23/2010	King Fire & Saffey	16832	Emergency Light-4.5 amps Battery & Labor	182.90
1924	7/23/2010	Richard Terpstra	RT-0715	Reim for BOCCE Set & Scoring Kit	102.68
1925	7/23/2010	Security Alarm Corp.	85714	Service -Comm- Fire & 12 Volt Battery	170.00
1926	7/23/2010	Symbiont Service Corp.	44761	Repairs/Replace Pool Temp Gage	90.00
Report Total					43,618.11



that was easy.

ACCOUNT SUMMARY

Previous Balance	\$ 272.94	Closing Date	06/15/10	LAKESIDE PLANTATION CDD BILL CAPOZZI 6131 LYONS RD STE 100 COCONUT CREEK, FL 33073-4739	
Payments	-\$ 272.94	Next Closing Date	07/16/10		
Credits	-\$ 0.00	Payment Due Date	07/10/10		
Purchases	+\$ 471.93				
Debits	+\$ 0.00	Current Due	\$ 25.00	Credit Line	\$ 750
FINANCE CHARGES	+\$ 0.00	Past Due Amount	+\$ 0.00	Credit Available	\$ 278
Late Fees	+\$ 0.00	Minimum Payment Due	=\$ 25.00		
New Balance	=\$ 471.93				

View, Manage and Pay online @ <http://www.staples.accountonline.com>

CURRENT ACTIVITY

Transaction Date	Location/Description	Amount
MAY 21	#3138504903-000-001 ORLANDO FL	96.96
JUN 4	OFFICE SUPPLIES VENICE FL	374.97
PAYMENTS, CREDITS, FEES, and ADJUSTMENTS		
JUN 7	PAYMENT - REF # P919400HF09SE629K	272.94-

Thank you for being a valued Staples Rewards member. Being a Staples credit member now entitles you to receive FREE delivery on ALL of your orders! Add your Staples Rewards number to your profile on Staples.com and earn free shipping for all orders.

FINANCE CHARGE SUMMARY

REGULAR REVOLVE CREDIT PLAN	Current Billing Period				Previous Billing Period			
	Balance Subject to Finance Charge	Daily Periodic Rate	Days in Billing Period	ANNUAL PERCENTAGE RATE	Balance Subject to Finance Charge	Daily Periodic Rate	Days in Billing Period	ANNUAL PERCENTAGE RATE
	0.00	.06572	30	23.99	0.00	.06572	31	23.99

This Account Issued by Citibank (South Dakota), N.A. CUSTOMER SERVICE 1-800-767-1291 FAX NUMBER 1-801-779-7425

Make checks payable to: STAPLES CREDIT PLAN Payment must be received by 5:00 p.m. local time on Payment Due Date.

Payment Due Date	New Balance	Minimum Payment Due	Amount of Enclosed Payment
07/10/10	\$ 471.93	\$ 25.00	\$

FOR PROPER CREDIT, PLEASE WRITE ON CHECK AND ENCLOSE WITH THIS STUB.

Mail Payments to:

Make Address Changes Below

Dept. 51 - 7872428692
STAPLES CREDIT PLAN
PO BOX 689020
DES MOINES IA 50368-9020

LAKESIDE PLANTATION CDD
BILL CAPOZZI
6131 LYONS RD STE 100
COCONUT CREEK, FL 33073-4739

0030420
BB
XSCR



603551787242869200471930000000002500

STAPLES CREDIT PLAN
 DEPT.51 - 7872428692
 PO BOX 689020
 DES MOINES IA 50368-9020

ACCOUNT: 1804903001
 LAKESIDE PLANTATION CDD
 6131 LYONS RD STE 100



that was easy™

Payment Due Date: 07/10/10

Please make checks payable to STAPLES CREDIT PLAN

SHIP TO: LAURA WEST LAKESIDE PLANTATION 2209 PLANTATION BLVD NORTH PORT FL 80000	INVOICE: 1804903001	SHIP TO: 	INVOICE: 53436
Ship To: Store: 100009412	AMOUNT DUE: 96.96 INVOICE DATE: 05/21 /10	Store: 100006491	AMOUNT DUE: 374.97 INVOICE DATE: 06/04 /10
BIC SEPTEMBER INSERT09 000395410 HP 80XL BLACK INK 000618609 HP 80 XL CYAN INK 000618610 HP 80XL MAGENTA INK 000618612 HP 80 XL YELLOW INK 000618613 FREE PIP INSERT - DEC P 000713311 Coupon 9427457538646	1 EA 0.00 0.00 1 EA 40.99 40.99 1 EA 26.99 26.99 1 EA 26.99 26.99 1 EA 26.99 26.99 1 EA 0.00 0.00 1 25.00- 25.00-	HP OJPRO 8500 WIRELESS 777063 3YR TSP PTR/FX/ALL\$200- 587651 VENDOR FUNDED COUPON 558099	1 EA 399.98 399.98 1 EA 74.99 74.99 1 EA 100.00- 100.00-
SUBTOTAL 96.96 TAX 0.00 SHIPPING 0.00 TOTAL 96.96		SUBTOTAL 374.97 TAX 0.00 SHIPPING 0.00 TOTAL 374.97	

Please Direct Inquiries to: Phone: 800-767-1291 Fax: 801-779-7425

HOME DEPOT CREDIT SERVICES
 Dept 32-2502829538
 PO BOX 9055
 DES MOINES, IA 50368-9055

Statement of Account Activity
 As of 07/05/2010



Account Number:

Page 1 of 4

115952

LAKESIDE PLANTATION CDD
 2002 N LOUIS AVE., STE. 507
 TAMPA FL 33607-2393

0038762
 6
 EI
 01
 06
 0062117
 HEPR

Please Pay
 This Amount: 363.20

Payment
 Due Date: 07/25/2010

Pay Online @myhomedepotaccount.com



Summary of Account Activity

Previously Billed Open Items	Current Payments, Adjustments and Unapplied Cash	Current Purchases, Returns and Fees
.00	128.25-	363.20

Transaction Detail

Current Purchases, Returns and Fees

TRANSACTION DATE	INVOICE NUMBER	PURCHASE ORDER/ JOB NAME	LOCATION / DESCRIPTION	ORIGINAL SALES AMOUNT
06/05/2010	4060717		THE HOME DEPOT PORT CHARLOTT FL	7.48
06/14/2010	5571084		THE HOME DEPOT PORT CHARLOTT FL	9.13
06/21/2010	8022753		THE HOME DEPOT NORTH PORT FL	23.51
06/29/2010	63376		THE HOME DEPOT PORT CHARLOTT FL	303.08
07/01/2010	FCH-003795189		THE HOME DEPOT ATLANTA GA	20.00
Total				363.20

Current Payments, Adjustments and Unapplied Cash

TRANSACTION DATE	DESCRIPTION	AMOUNT
07/02/2010	Payment	128.25 -
Total		128.25 -

Previously Billed Open Items

TRANSACTION DATE	INVOICE NUMBER	DUE DATE	LOCATION / DESCRIPTION	CURRENT AMOUNT DUE
------------------	----------------	----------	------------------------	--------------------

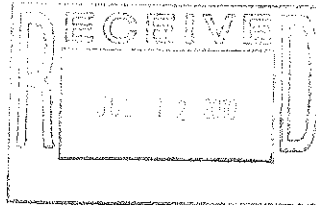

Questions About Your Account

ACCOUNT MANAGER
 HOME DEPOT CREDIT SERVICES
 MAIL
 PO BOX 9121
 DES MOINES IA 50368-9121

FAX
 (877)969-6751

PHONE
 (800)395-7363

EMAIL
 PROX.LAYTON@HOMEDEPOTCREDITSERVICES.COM

Remit Payment To:
 HOME DEPOT CREDIT SERVICES
 PO BOX 9055
 DES MOINES, IA 50368-9055

ACCOUNT:
 LAKESIDE PLANTATION CDD
 2002 N LOUIS AVE., STE. 507
 TAMPA FL 33607-2393

115954

Payment Due Date: 07/25/2010
 Please make checks payable to: HOME DEPOT CREDIT SERVICES



Acct #: LAKESIDE PLANTATION CDD

Purchased by: TERPSTRA RICHARD
Invoice: 4060717

Ship To:
Purchase Order/ Job Name:

Amount Due: 7.48

Customer Agreement #: Transaction Date: 06/05/2010

Store #, Location: 0201, PORT CHARLOTT

SKU #	PRODUCT	QTY	UNIT PRICE	TOTAL PRICE
0000438557	TAPE 1000FT	1.0000	EA 7.48	7.48
SUBTOTAL				7.48
TAX				0.00
SHIPPING				0.00
TOTAL				7.48

Acct #: LAKESIDE PLANTATION CDD

Purchased by: TERPSTRA RICHARD
Invoice: 5571064

Ship To:
Purchase Order/ Job Name:

Amount Due: 9.13

Customer Agreement #: Transaction Date: 06/14/2010

Store #, Location: 0201, PORT CHARLOTT

SKU #	PRODUCT	QTY	UNIT PRICE	TOTAL PRICE
0000299648	BIN NTLT1100	1.0000	PK 4.88	4.88
0000619375	2X4 HARDBD	1.0000	EA 4.14	4.14
SUBTOTAL				9.13
TAX				0.00
SHIPPING				0.00
TOTAL				9.13

Acct #: LAKESIDE PLANTATION CDD

Purchased by: TERPSTRA RICHARD
Invoice: 8022753

Ship To:
Purchase Order/ Job Name:

Amount Due: 23.51

Customer Agreement #: Transaction Date: 06/21/2010

Store #, Location: 8528, NORTH PORT

SKU #	PRODUCT	QTY	UNIT PRICE	TOTAL PRICE
0000323343	50#CNVPICHK	1.0000	EA 0.97	0.97
0000728900	PUSHBROOM	1.0000	EA 19.97	19.97
0000323343	50#CNVPICHK	1.0000	EA 0.97	0.97
0000189855	FITTING	1.0000	EA 1.16	1.16
0000562436	1G WP WH	1.0000	EA 0.44	0.44
SUBTOTAL				23.51
TAX				0.00
SHIPPING				0.00
TOTAL				23.51

Acct #: LAKESIDE PLANTATION CDD

Purchased by: TERPSTRA RICHARD
Invoice: 63376

Ship To:
Purchase Order/ Job Name:

Amount Due: 303.08

Customer Agreement #: Transaction Date: 06/29/2010

Store #, Location: 0201, PORT CHARLOTT

SKU #	PRODUCT	QTY	UNIT PRICE	TOTAL PRICE
0000436493	PYLAM COVER	1.0000	EA 4.77	4.77
0000318402	12"SWRPLRPFM	1.0000	EA 4.98	4.98
0000422599	14W MINI 4PK	1.0000	EA 5.85	5.85
0000461101	SEALER	1.0000	EA 24.96	24.96
0000104433	NPL CASE	1.0000	CA 3.97	3.97
0000461101	SEALER	10.0000	EA 24.96	249.60
-continued				

Remit Payment To:
 HOME DEPOT CREDIT SERVICES
 PO BOX 9055
 DES MOINES, IA 50368-9055

ACCOUNT
 LAKESIDE PLANTATION CDD
 2002 N LOUIS AVE., STE. 507
 TAMPA FL 33607-2393

Page 4 of 4
 115955



Payment Due Date: 07/25/2010
 Please make checks payable to: HOME DEPOT CREDIT SERVICES

Acct # LAKESIDE PLANTATION CDD Purchased by: TERPSTRA RICHARD Invoice: 63376 Ship To: Purchase Order/ Job Name: Amount Due: 303.08 Customer Agreement #: Transaction Date: 06/29/2010 Store #, Location: 0201, PORT CHARLOTT					Acct # LAKESIDE PLANTATION CDD Purchased by: Invoice: FCH-003795189 Ship To: Purchase Order/ Job Name: Amount Due: 20.00 Customer Agreement #: Transaction Date: 07/01/2010 Store #, Location: 0000, ATLANTA																																																													
<table border="1"> <thead> <tr> <th>SKU #</th> <th>PRODUCT</th> <th>QTY</th> <th>UNIT PRICE</th> <th>TOTAL PRICE</th> </tr> </thead> <tbody> <tr> <td>0000156526</td> <td>12"PLSPNITRY</td> <td>1.0000</td> <td>EA 4.96</td> <td>4.96</td> </tr> <tr> <td>0000104433</td> <td>NPL CASE</td> <td>1.0000</td> <td>CA 3.97</td> <td>3.97</td> </tr> <tr> <td colspan="4">SUBTOTAL</td> <td>303.08</td> </tr> <tr> <td colspan="4">TAX</td> <td>0.00</td> </tr> <tr> <td colspan="4">SHIPPING</td> <td>0.00</td> </tr> <tr> <td colspan="4">TOTAL</td> <td>303.08</td> </tr> </tbody> </table>	SKU #	PRODUCT	QTY	UNIT PRICE	TOTAL PRICE	0000156526	12"PLSPNITRY	1.0000	EA 4.96	4.96	0000104433	NPL CASE	1.0000	CA 3.97	3.97	SUBTOTAL				303.08	TAX				0.00	SHIPPING				0.00	TOTAL				303.08	<table border="1"> <thead> <tr> <th>SKU #</th> <th>PRODUCT</th> <th>QTY</th> <th>UNIT PRICE</th> <th>TOTAL PRICE</th> </tr> </thead> <tbody> <tr> <td>0000</td> <td>LATE FEE</td> <td>1.0000</td> <td>20.00</td> <td>20.00</td> </tr> <tr> <td colspan="4">SUBTOTAL</td> <td>20.00</td> </tr> <tr> <td colspan="4">TAX</td> <td>0.00</td> </tr> <tr> <td colspan="4">SHIPPING</td> <td>0.00</td> </tr> <tr> <td colspan="4">TOTAL</td> <td>20.00</td> </tr> </tbody> </table>	SKU #	PRODUCT	QTY	UNIT PRICE	TOTAL PRICE	0000	LATE FEE	1.0000	20.00	20.00	SUBTOTAL				20.00	TAX				0.00	SHIPPING				0.00	TOTAL				20.00
SKU #	PRODUCT	QTY	UNIT PRICE	TOTAL PRICE																																																														
0000156526	12"PLSPNITRY	1.0000	EA 4.96	4.96																																																														
0000104433	NPL CASE	1.0000	CA 3.97	3.97																																																														
SUBTOTAL				303.08																																																														
TAX				0.00																																																														
SHIPPING				0.00																																																														
TOTAL				303.08																																																														
SKU #	PRODUCT	QTY	UNIT PRICE	TOTAL PRICE																																																														
0000	LATE FEE	1.0000	20.00	20.00																																																														
SUBTOTAL				20.00																																																														
TAX				0.00																																																														
SHIPPING				0.00																																																														
TOTAL				20.00																																																														



Savings Made Simple



Exclusively for Sam's Club Plus®

District Administrator Approval _____
 Fund Type _____
 Fund Code _____
 GL Code _____
 Object Code _____
 Date Entered _____
 Check Number _____

Members eValues are additional discounts and offers loaded right on your Membership card.

Visit samsclub.com/evalues to see how much more you can save.

Sam's Club® Credit

LAKESIDE PLANTATION
Account Number:

Visit us at samsclub.com/credit
Member Service: 1-800-203-5764

0-158
1-2

Summary of Account Activity		Payment Information	
Previous Balance	\$417.29	New Balance	\$860.35
+ Purchases/Debits	\$390.39	Minimum Payment This Period	\$50.00
+ Fees Charged	\$39.99	Amount Past Due	\$50.00
+ Interest Charges	\$12.88	Total Minimum Payment Due	\$100.00
New Balance	\$860.35	Payment Due Date	07/22/2010
Credit Limit	\$2,500.00		
Available Credit	\$1,602.00		
Statement Closing Date	06/27/2010		
Days in Billing Cycle	31		

Transaction Summary				
Tran Date	Post Date	Reference Number	Description of Transaction or Credit	Amount
08/05	06/05	P928000HF01DAZ0ZM	MURDOCK CIR PT CHARLOTTE FL	\$177.85
			TOTAL FOR AUTHORIZED BUYER NO 14	\$177.85
06/01	06/01	P928000HB01A66ZY2	MURDOCK CIR PT CHARLOTTE FL	\$70.70
06/11	06/11	P928000HM01HSY4RN	MURDOCK CIR PT CHARLOTTE FL	\$33.40
06/13	06/13	P928000HP01KA6KWP	MURDOCK CIR PT CHARLOTTE FL	\$19.46
06/18	06/18	P928000HW01P8NR5S	MURDOCK CIR PT CHARLOTTE FL	\$88.98
			TOTAL FOR AUTHORIZED BUYER NO 41	\$212.54
			FEES	
06/21	06/21		LATE FEE	\$39.99
			TOTAL FEES FOR THIS PERIOD	\$39.99
			INTEREST CHARGED	
06/27	06/27		INTEREST CHARGE ON PURCHASES	\$12.88

Late Fee removed

PAYMENT DUE BY 5 P.M. (ET) ON THE DUE DATE.

NOTICE: We may convert your payment into an electronic debit. See reverse side for details, Billing Rights and other important information.

MEMBER SERVICE: For Account Information log on to samsclub.com/credit. This account is registered. See your On-line Administrator to get a User ID & Password. Or call toll-free 1-800-203-5764.

LAKESIDE PLANTATION

ACCOUNT #: DATE OF SALE #: 100601 P.O. #:
 INVOICE# 000534 AUTHORIZATION :# 000460 CLUB #: 6445
 REFERENCE # P928000HB01A66ZY2 TRANSACTION #: 534 REGISTER #: 12

S.K.U	DESCRIPTION	QUANTITY	UNIT	PRICE	EXT. PRICE
000599389	CUP FOAM 8 OZ 1000CT	1.000	EA	\$13.8800	\$13.88
003680819	WINDEX	1.000	EA	\$8.8800	\$8.88
004858652	LYSOL TOILET CLEANER	1.000	EA	\$7.7200	\$7.72
005529094	COLD CUP 5 OZ	1.000	EA	\$8.8600	\$8.86
006915186	POM 2PLY BATH TISSUE	1.000	EA	\$18.8800	\$18.88
020737585	SCOTT PAPER TOWELS	1.000	EA	\$12.4800	\$12.48
SUB \$70.70		TAX \$0.00		TOTAL INVOICE	\$70.70
				CREDITS TOTAL	\$0.00
				BALANCE DUE	\$70.70

LAKESIDE PLANTATION

ACCOUNT #: DATE OF SALE #: 100605 P.O. #:
 INVOICE# 001123 AUTHORIZATION :# 000571 CLUB #: 6445
 REFERENCE # P928000HF01DAZ0ZM TRANSACTION #: 1123 REGISTER #: 13

S.K.U	DESCRIPTION	QUANTITY	UNIT	PRICE	EXT. PRICE
000030589	WHITE- NC- 4	4.000	EA	\$3.1600	\$12.64
000038443	ICE	4.000	EA	\$2.6200	\$10.48
002885228	ZEPHYRHILLS	1.000	EA	\$3.9800	\$3.98
004210238	WHITE- CS- 6"	6.000	EA	\$1.9800	\$11.88
005290535	PRAIRE RIDGE BF PATT	3.000	EA	\$20.8900	\$62.67
005333733	LAYS CLASSIC	1.000	EA	\$11.2200	\$11.22
005447348	WISE VARIETY PACK	1.000	EA	\$8.6800	\$8.68
005631493	AMERICAN SLICES	1.000	EA	\$9.1200	\$9.12
021457240	DIET COKE	1.000	EA	\$5.9800	\$5.98
021640242	SUNKIST ORANGE	1.000	EA	\$2.9800	\$2.98
021833561	BEEF FRANKS	4.000	EA	\$5.8200	\$23.28
021876973	POPPIES CRM PUFFS	2.000	EA	\$5.9800	\$11.96
021899145	A&W ROOT BEER	1.000	EA	\$2.9800	\$2.98
SUB \$177.85		TAX \$0.00		TOTAL INVOICE	\$177.85
				CREDITS TOTAL	\$0.00
				BALANCE DUE	\$177.85

LAKESIDE PLANTATION

ACCOUNT #: DATE OF SALE #: 100611 P.O. #:
 INVOICE# 002127 AUTHORIZATION :# 000433 CLUB #: 6445
 REFERENCE # P928000HM01HSY4RN TRANSACTION #: 2127 REGISTER #: 11

S.K.U	DESCRIPTION	QUANTITY	UNIT	PRICE	EXT. PRICE
005617804	FRENCH BREAD 2 CT	1.000	EA	\$2.5400	\$2.54
021457132	SPRITE	1.000	EA	\$5.9800	\$5.98
021457286	CLASSIC	1.000	EA	\$5.9800	\$5.98
021640242	SUNKIST ORANGE	1.000	EA	\$2.9800	\$2.98
021751931	PEPSI	1.000	EA	\$5.9800	\$5.98
021773596	NESTLE PURE LIFE	1.000	EA	\$3.9800	\$3.98
021898962	CANADA DRY GINGERALE	1.000	EA	\$2.9800	\$2.98
021899145	A&W ROOT BEER	1.000	EA	\$2.9800	\$2.98
SUB \$33.40		TAX \$0.00		TOTAL INVOICE	\$33.40
				CREDITS TOTAL	\$0.00
				BALANCE DUE	\$33.40

LAKESIDE PLANTATION

ACCOUNT #: DATE OF SALE #: 100613 P.O. #:
 INVOICE# 000348 AUTHORIZATION :# 000421 CLUB #: 6445
 REFERENCE # P928000HP01KA6KWP TRANSACTION #: 348 REGISTER #: 5

S.K.U	DESCRIPTION	QUANTITY	UNIT	PRICE	EXT. PRICE
005480662	SKINNY COW ICE CREAM	1.000	EA	\$9.8800	\$9.88

1-1-28

Lakeside Plantation Community Development District

Financial Statements
(Unaudited)

Period Ending
August 31, 2010



DMS

District Management Services, LLC

District Management Services, LLC
2002 North Lois Avenue ~ Suite 507 ~ Tampa, Florida 33607-2393
Phone (813) 873-7300 ~ Fax (813) 873-7070

Lakeside Plantation Community Development District

Balance Sheet

As of 8/31/2010

(In Whole Numbers)

	General Fund	Debt Service Fund	General Fixed Assets Account Group	General Long-Term Debt Account Group	TOTAL
Assets					
Cash	3,629	0	0	0	3,629
Investments--Current	394,783	90,565	0	0	485,348
Prepaid Items	4,926	0	0	0	4,926
Due From Other Funds	0	940	0	0	940
Amount Available In Debt Service Fund	0	0	0	91,505	91,505
Amount To Be Provided Debt Service	0	0	0	1,913,495	1,913,495
Fixed Assets	0	0	7,606,752	0	7,606,752
Total Assets	403,338	91,505	7,606,752	2,005,000	10,106,595
Liabilities					
Accounts Payable	15,106	0	0	0	15,106
Accrued Expenses Payable	1,003	0	0	0	1,003
Due To Other Funds	940	0	0	0	940
Revenue Bonds Payable--Long Term	0	0	0	2,005,000	2,005,000
Total Liabilities	17,049	0	0	2,005,000	2,022,049
Fund Equity & Other Credits Contributed Capital					
Investment In General Fixed Assets	0	0	7,606,752	0	7,606,752
Fund Balance--Reserved	0	86,681	0	0	86,681
Fund Balance--Unreserved	310,323	0	0	0	310,323
Net Changes In Fund Balances For Year	75,967	4,824	0	0	80,790
Total Fund Equity & Other Credits Contributed Capital	386,289	91,505	7,606,752	0	8,084,546
Total Liabilities & Fund Equity	403,338	91,505	7,606,752	2,005,000	10,106,595

Lakeside Plantation Community Development District

Income Stmt - GF

General Fund - 001

From 10/1/2009 Through 8/31/2010

(In Whole Numbers)

	Annual Budget	Current Period Actual	Budget to Actual Variance	Budget Percent Remaining
Revenues				
Special Assessments - Service Charges				
Operations & Maintenance Assmts-Tax Roll	651,844	660,743	8,899	1.36%
Total Special Assessments - Service Charges	651,844	660,743	8,899	1.37%
Interest Earnings				
Interest Earnings	2,000	1,809	(191)	(9.56)%
Total Interest Earnings	2,000	1,809	(191)	(9.57)%
Other Miscellaneous Revenues				
Miscellaneous	0	3,572	3,572	0.00%
Clubhouse Rentals	3,000	2,293	(707)	(23.55)%
Activities	7,000	7,544	544	7.77%
Tennis Club	15,000	13,323	(1,677)	(11.17)%
Total Other Miscellaneous Revenues	25,000	26,733	1,733	6.93%
Total Revenues	678,844	689,285	10,441	1.54%
Expenditures				
Legislative				
Supervisor Fees	9,000	10,400	(1,400)	(15.55)%
Payroll Taxes	700	306	394	56.28%
Total Legislative	9,700	10,706	(1,006)	(10.37)%
Financial & Administrative				
District Manager	46,500	42,517	3,983	8.56%
District Engineer	7,000	820	6,180	88.28%
Disclosure Report	0	1,000	(1,000)	0.00%
Trustees Fees	0	993	(993)	0.00%
Assessment Roll	5,000	1,250	3,750	75.00%
Professional Fees	0	3,900	(3,900)	0.00%
Audit Fees	8,300	8,000	300	3.61%
Public Communications	250	112	138	55.20%
General Liability Insurance	6,000	4,416	1,584	26.40%
Postage	900	253	647	71.94%
Printing & Binding	1,000	431	569	56.86%
Legal Advertising	1,500	469	1,031	68.72%
Dues, Licenses & Fees	175	175	0	0.00%
Other Current Charges	2,200	1,460	740	33.61%
Total Financial & Administrative	78,825	65,796	13,029	16.53%
Legal Counsel				
District Counsel	12,000	21,301	(9,301)	(77.50)%
Total Legal Counsel	12,000	21,301	(9,301)	(77.51)%

Lakeside Plantation Community Development District

Income Stmt - GF

General Fund - 001

From 10/1/2009 Through 8/31/2010

(In Whole Numbers)

	Annual Budget	Current Period Actual	Budget to Actual Variance	Budget Percent Remaining
General Maintenance				
Personnel Services	115,000	148,687	(33,687)	(29.29)%
Payroll Taxes	8,798	9,806	(1,008)	(11.45)%
Health Insurance	10,000	4,113	5,887	58.86%
Workers' Comp Insurance	4,000	2,678	1,322	33.05%
Temp Services	5,000	164	4,836	96.72%
Travel Reimbursement	1,800	561	1,239	68.83%
Roadway Maintenance	10,000	16,593	(6,593)	(65.93)%
Common Area Maintenance	9,000	5,911	3,089	34.32%
Common Area Renewal & Replacement	1,000	0	1,000	100.00%
Street Lighting	6,000	4,826	1,174	19.57%
Lawn Service/Landscaping-Contractual	76,941	67,600	9,341	12.14%
Plant Replacement Program	7,016	930	6,086	86.74%
Irrigation Maintenance	2,500	1,877	623	24.93%
Lake Maintenance	11,742	9,526	2,216	18.87%
Lake Bank Restoration	10,000	0	10,000	100.00%
Entrance Feature - Electric	8,500	5,359	3,141	36.95%
Entrance Feature-Utilities/Water	6,000	5,662	338	5.63%
Entrance Feature - Repairs/Maint.	6,000	2,844	3,156	52.60%
Misc. Tools, Equipment & Supplies	2,500	2,290	210	8.39%
Total General Maintenance	301,797	289,426	12,371	4.10%
Clubhouse/Pool/Tennis Courts				
Clubhouse - Activities	19,000	16,482	2,518	13.25%
Clubhouse - General Supplies	1,775	3,427	(1,652)	(93.08)%
Clubhouse - Maintenance	6,000	6,479	(479)	(7.97)%
Clubhouse - Renewal & Replacements	5,000	8,594	(3,594)	(71.87)%
Clubhouse - Office Supplies	2,000	2,397	(397)	(19.86)%
Clubhouse - Pest Control	750	750	0	0.00%
Clubhouse - Security	2,000	7,395	(5,395)	(269.73)%
Clubhouse - AED	5,000	2,430	2,570	51.40%
Clubhouse - Telephone & Internet	3,000	3,130	(130)	(4.31)%
Clubhouse - Exercise Equipment	11,092	7,170	3,922	35.35%
Clubhouse - Furniture	2,000	785	1,215	60.75%
Clubhouse - Janitorial Supplies	1,600	1,262	338	21.13%
Clubhouse/Tennis - Electric	9,000	10,331	(1,331)	(14.79)%
Clubhouse - Gas	150	147	3	2.15%
Club/Pool - Waste Removal/Refuse	2,000	1,131	869	43.45%
Clubhouse/Pool - Water & Sewer	2,000	1,948	52	2.59%
Pool - Electric	20,000	16,197	3,803	19.01%

Lakeside Plantation Community Development District

Income Stmt - GF

General Fund - 001

From 10/1/2009 Through 8/31/2010

(In Whole Numbers)

	Annual Budget	Current Period Actual	Budget to Actual Variance	Budget Percent Remaining
Pool - Furniture	2,400	2,943	(543)	(22.62)%
Pool - Maintenance	7,000	7,994	(994)	(14.20)%
Tennis Court - Maintenance	3,500	3,009	491	14.01%
Tennis Court - Programs	3,000	2,492	508	16.93%
Tennis Court - Water	3,000	6,572	(3,572)	(119.06)%
Total Clubhouse/Pool/Tennis Courts	111,267	113,065	(1,798)	(1.62)%
Other Expenses				
Contingencies	84,285	52,975	31,310	37.14%
Property Taxes	45,000	42,275	2,725	6.05%
Property Insurance	15,000	7,237	7,763	51.75%
Permit Fees	600	675	(75)	(12.50)%
Property Appraiser Fees	10,185	0	10,185	100.00%
Tax Collector Fees	10,185	9,862	323	3.17%
Total Other Expenses	165,255	113,024	52,231	31.61%
Total Expenditures	678,844	613,318	65,526	9.65%
Subtotal: Rev Over / (Under) Exp	0	75,967	75,967	0.00%
Total: Revenues Over / Under Expenditures	0	75,967	75,967	0.00%

Lakeside Plantation Community Development District

Statement of Revenues and Expenditures

Debt Service Fund - 200

From 10/1/2009 Through 8/31/2010

(In Whole Numbers)

	Annual Budget	Current Period Actual	Budget to Actual Variance	Budget Percent Remaining
Revenues				
Special Assessments - Capital Improvements				
Debt Service Assmts-Tax Roll	187,186	189,744	2,558	1.36%
Interest Earnings				
Interest Earnings	0	40	40	0.00%
Total Revenues	<u>187,186</u>	<u>189,783</u>	<u>2,597</u>	<u>1.39%</u>
Expenditures				
Debt Service Payments				
Interest Payments	142,128	142,128	1	0.00%
Principal Payments	45,000	40,000	5,000	11.11%
Other Expenses				
Tax Collector Fees	2,924	2,832	92	3.14%
Total Expenditures	<u>190,052</u>	<u>184,960</u>	<u>5,092</u>	<u>2.68%</u>
Excess of Revenues Over (Under) Expenditures	<u>(2,866)</u>	<u>4,824</u>	<u>7,690</u>	<u>(268.31)%</u>
Exc of Rev./Other Sources Over Expend./Other Uses	<u>(2,866)</u>	<u>4,824</u>	<u>7,690</u>	<u>(268.31)%</u>

Lakeside Plantation Community Development District
Reconcile Cash Accounts

Reconciliation Date: 8/31/2010
Cash Account: 10101 Cash-BB&T Operating A/C

Bank Balance	45,738.89
Less Outstanding Checks/Vouchers	44,002.14
Plus Deposits <i>in Transit</i>	0.00
Plus or Minus Other Cash Items	0.00
Plus or Minus Suspense Items	<u>0.00</u>
Reconciled Bank Balance	1,736.75
Balance Per Books	<u>1,736.75</u>
Unreconciled Difference	<u><u>0.00</u></u>

**Lakeside Plantation Community Development District
Reconcile Cash Accounts
Outstanding Checks/Vouchers**

Reconciliation Date: 8/31/2010

Cash Account: 10101 Cash-BB&T Operating A/C

<u>Document Number</u>	<u>Document Date</u>	<u>Document Description</u>	<u>Document Amount</u>	<u>Payee</u>
1726	3/11/2010	System Generated Check/Voucher	200.00	David Polk
1810	5/15/2010	System Generated Check/Voucher	50.00	Mike Stewart
1878	6/25/2010	System Generated Check/Voucher	400.00	David Polk
1955	8/17/2010	System Generated Check/Voucher	200.00	Ronald Bock
1960	8/18/2010	System Generated Check/Voucher	200.00	David Polk
1961	8/30/2010	System Generated Check/Voucher	396.87	Comcast Communications
1962	8/30/2010	System Generated Check/Voucher	300.00	Lisa Cantillo
1963	8/30/2010	System Generated Check/Voucher	542.50	Shumaker, Loop & Kendrick LLP
1964	8/30/2010	System Generated Check/Voucher	12.77	TECO Peoples Gas
1965	8/30/2010	System Generated Check/Voucher	41,700.00	Teixeira Construction, Inc.
Outstanding Checks/Vouchers			44,002.14	



864-02-01-00 50368 35 C 001 24 55 004
 LAKESIDE PLANTATION CDD
 2002 N LOIS AVE STE 507
 TAMPA FL 33607 - 2393

Your consolidated statement

For 08/31/2010

Contact us



BBT.com



(800) BANK-BBT or
 (800) 226-5228

A Strong Employee Benefits Package Can Give Your Company a Competitive Edge

Today, more than ever, resources are tight. At BB&T, we are committed to ensuring you have the right solutions to keep your costs under control while helping you attract and retain your most valuable resource - your employees.

The BB&T@Work program is an exclusive financial package available to your employees that provides valuable savings on a wide range of BB&T products and services. BB&T@Work:

- Is a no-cost enhancement to your employee benefits package
- Encourages direct deposit of payroll
- Promotes employee financial well-being
- Requires no additional time investment from you for support

For more information on how your company can take advantage of BB&T@Work, visit your nearest BB&T financial center or www.BBT.com/atwork.

Member FDIC

Summary of your accounts

ACCOUNT NAME	ACCOUNT NUMBER	BALANCE(\$)	DETAILS ON
BASIC PUBLIC FUND CHECKING		45,738.89	page 1
PUBLIC FUND MONEY RATE SAVINGS		394,389.68	page 2
Total checking and money market savings accounts		\$440,128.57	



Checking and money market savings accounts

■ BASIC PUBLIC FUND CHECKING

Former Account Number

Account summary

Your previous balance as of 07/30/2010	\$4,139.01
Checks	- 34,400.12
Other withdrawals, debits and service charges	- 0.00
Deposits, credits and interest	+ 76,000.00
Your new balance as of 08/31/2010	= \$45,738.89

■ BASIC PUBLIC FUND CHECKING

____ Former Account Number

Checks

DATE	CHECK #	AMOUNT(\$)	DATE	CHECK #	AMOUNT(\$)	DATE	CHECK #	AMOUNT(\$)
08/03	1919	305.00	08/03	1936	12.77	08/16	1948	147.00
08/03	*1922	244.20	08/02	1937	183.60	08/17	1949	381.37
08/04	*1924	102.68	08/09	1938	349.00	08/16	1950	145.44
08/04	*1927	80.00	08/03	1939	132.48	08/16	1951	6,100.00
08/03	1928	216.00	08/19	1940	161.50	08/23	1952	67.50
08/02	1929	9,816.67	08/16	1941	6,025.00	08/20	1953	200.00
08/03	1930	201.77	08/17	1942	866.00	08/24	1954	200.00
08/03	1931	947.68	08/16	1943	2.37	08/24	*1956	200.00
08/03	1932	1,234.34	08/17	1944	96.00	08/23	1957	200.78
08/12	1933	3,300.00	08/17	1945	561.08	08/25	1958	785.00
08/18	1934	4.19	08/17	1946	20.82	08/20	1959	144.70
08/03	1935	840.00	08/17	1947	125.18			

* indicates a skip in sequential check numbers above this item

Total checks = \$34,400.12

Deposits, credits and interest

DATE	DESCRIPTION	AMOUNT(\$)
08/02	BB&T ONLINE TRANSFER TRANSFER FROM CHECKING	20,000.00
08/13	BB&T ONLINE TRANSFER TRANSFER FROM CHECKING	15,000.00
08/31	BB&T ONLINE TRANSFER TRANSFER FROM CHECKING	41,000.00
Total deposits, credits and interest		= \$76,000.00

■ PUBLIC FUND MONEY RATE SAVINGS

— Former Account Number

Account summary

Your previous balance as of 07/31/2010	\$467,048.13
Checks	- 0.00
Other withdrawals, debits and service charges	- 77,000.00
Deposits, credits and interest	+ 4,341.55
Your new balance as of 08/31/2010	= \$394,389.68

Interest summary

Interest paid this statement period	\$129.99
2010 interest paid year-to-date	\$1,212.71
Interest rate	0.35%
Annual percentage yield (APY) earned	0.35%

Other withdrawals, debits and service charges

DATE	DESCRIPTION	AMOUNT(\$)
08/02	BB&T ONLINE TRANSFER TRANSFER TO CHECKING	20,000.00
08/04	BB&T ONLINE TRANSFER TRANSFER TO CHECKING	1,000.00
08/13	BB&T ONLINE TRANSFER TRANSFER TO CHECKING	15,000.00
08/31	BB&T ONLINE TRANSFER TRANSFER TO CHECKING	41,000.00
Total other withdrawals, debits and service charges		= \$77,000.00

Deposits, credits and interest

DATE	DESCRIPTION	AMOUNT(\$)
08/25	TAX DIST SARASOTA CO TAX LAKESIDE PLANTATION	4,211.56
08/31	INTEREST PAYMENT	129.99
Total deposits, credits and interest		= \$4,341.55

Amendment to the Business Services Pricing Guide

The following changes are being made to the *Business Services Pricing Guide* that you received when you opened your BB&T account. Continued use of your account after October 1, 2010, constitutes your acceptance of the changes. If you do not have a copy of the *Business Services Pricing Guide*, you may obtain an updated version at your local BB&T financial center, or if you have questions with your account, call 1-800-BANK BBT (1-800-226-5228).

Effective October 1, 2010

Depository Services:

Non-Depositor Check Cashing Fee for On Us (BB&T) Checks (Applies only to checks cashed greater than \$50.00)	\$6.00
---	--------

Lakeside Plantation Community Development District
Reconcile Cash Accounts

Reconciliation Date: 8/31/2010
Cash Account: 10102 Cash-BB&T Activities A/C

Bank Balance	1,984.98
Less Outstanding Checks/Vouchers	292.54
Plus Deposits in Transit	0.00
Plus or Minus Other Cash Items	0.00
Plus or Minus Suspense Items	<u>0.00</u>
Reconciled Bank Balance	1,692.44
Balance Per Books	<u>1,692.44</u>
Unreconciled Difference	<u><u>0.00</u></u>

Lakeside Plantation Community Development District
Reconcile Cash Accounts
Outstanding Checks/Vouchers

Reconciliation Date: 8/31/2010

Cash Account: 10102 Cash-BB&T Activities A/C

<u>Document Number</u>	<u>Document Date</u>	<u>Document Description</u>	<u>Document Amount</u>	<u>Payee</u>
2081	8/28/2010	End of Summer Supplies	16.94	Michael's
2082	8/28/2010	End of Summer Rentals	275.60	Do All Rental
Outstanding Checks/Vouchers			292.54	



864-02-01-00 50368 2 C 001 29 55 004
 LAKESIDE PLANTATION CDD
 ACTIVITIES ACCT
 2002 N LOIS AVE STE 507
 TAMPA FL 33607-2393

Your account statement

For 08/31/2010

Contact us



BBT.com



(800) BANK-BBT or
 (800) 226-5228

A Strong Employee Benefits Package Can Give Your Company a Competitive Edge

Today, more than ever, resources are tight. At BB&T, we are committed to ensuring you have the right solutions to keep your costs under control while helping you attract and retain your most valuable resource - your employees.

The BB&T@Work program is an exclusive financial package available to your employees that provides valuable savings on a wide range of BB&T products and services. BB&T@Work:

- Is a no-cost enhancement to your employee benefits package
- Encourages direct deposit of payroll
- Promotes employee financial well-being
- Requires no additional time investment from you for support

For more information on how your company can take advantage of BB&T@Work, visit your nearest BB&T financial center or www.BBT.com/atwork.

Member FDIC

■ BASIC PUBLIC FUND CHECKING

Former Account Number

Account summary

Your previous balance as of 07/30/2010	\$1,548.12
Checks	- 563.14
Other withdrawals, debits and service charges	- 0.00
Deposits, credits and interest	+ 1,000.00
Your new balance as of 08/31/2010	= \$1,984.98

Checks

DATE	CHECK #	AMOUNT(\$)
08/17	2078	63.14
08/30	* 2080	500.00
Total checks		= \$ 563.14

* indicates a skip in sequential check numbers above this item

Deposits, credits and interest

DATE	DESCRIPTION	AMOUNT(\$)
08/04	BB&T ONLINE TRANSFER TRANSFER FROM CHECKING	1,000.00
Total deposits, credits and interest		= \$1,000.00



State Board of Administration
LOCAL GOVERNMENT SURPLUS TRUST FUNDS INVESTMENT POOL
PARTICIPANT STATEMENT OF ACCOUNT
 FROM 8/1/2010 TO 8/31/2010
LGIP
 (formerly known as LGIP-A)
AGENCY ACCOUNT 211540

LAKESIDE PLANTATION
 COMMUNITY DEVELOPMENT DISTRICT
 2002 N LOIS AVE STE 507
 TAMPA, FL 33607

Participant Return: 0.35 %

Date	Transaction Type	Description	Amount	Balance
8/1/2010	BEGINNING BALANCE			93.20
8/5/2010	TRANSFER IN	RETURN OF FUNDS FROM LGIP B	4.82	98.02
8/31/2010	EARNED INCOME	INTEREST	0.03	98.05
Totals:			4.85	98.05

98.05
 295.11
 393.16

002

Fund B statements will be mailed separately by mid-month.

For questions regarding your statement, please call (850) 488-7311 or Suncom # 278-7311



State Board of Administration
LOCAL GOVERNMENT SURPLUS TRUST FUNDS INVESTMENT POOL
 PARTICIPANT STATEMENT OF ACCOUNT
 FROM 8/1/2009 TO 7/31/2010
FUND B
 (formerly known as LGIP-B)
AGENCY ACCOUNT 211540B

LAKESIDE PLANTATION
 COMMUNITY DEVELOPMENT DISTRICT
 2002 N LOIS AVE STE 507
 TAMPA, FL 33607

Date	Transaction Type	Description	Amount	Balance
8/1/2009	BEGINNING BALANCE			389.41
8/6/2009	TRANSFER OUT	DISTRIBUTION TO LGIP	(5.90)	383.51
9/4/2009	TRANSFER OUT	DISTRIBUTION TO LGIP	(7.24)	376.27
10/6/2009	TRANSFER OUT	DISTRIBUTION TO LGIP	(5.83)	370.44
11/5/2009	TRANSFER OUT	DISTRIBUTION TO LGIP	(4.89)	365.55
12/7/2009	TRANSFER OUT	DISTRIBUTION TO LGIP	(4.53)	361.02
1/7/2010	TRANSFER OUT	DISTRIBUTION TO LGIP	(25.20)	335.82
2/5/2010	TRANSFER OUT	DISTRIBUTION TO LGIP	(6.21)	329.61
3/5/2010	TRANSFER OUT	DISTRIBUTION TO LGIP	(4.42)	325.19
4/7/2010	TRANSFER OUT	DISTRIBUTION TO LGIP	(4.02)	321.17
5/6/2010	TRANSFER OUT	DISTRIBUTION TO LGIP	(5.20)	315.97
6/4/2010	TRANSFER OUT	DISTRIBUTION TO LGIP	(9.94)	306.03
7/8/2010	TRANSFER OUT	DISTRIBUTION TO LGIP	(6.10)	299.93
7/31/2010	PRINCIPAL BALANCE		<u>(89.48)</u>	<u>299.93</u>

% of Ownership: 0.00007243% *DISTRIBUTION 8/5 <4-82> 295-11*
 Ending NAV Balance: * 204.42
 Unrealized Gain (Loss): (95.51)

DISCLOSURE

Total NAV Fund B: 282,240,701.49
 Reserve Account: 0.00
 Total NAV for Participants: 282,240,701.49

* Ending NAV Balance represents your share of the Fund B NAV available for participants.
 For further information regarding the Reserve Account, please reference our website.

Lakeside Plantation
Community Development Districts
Special Assessment Receipts
Fiscal Year Ending September 30, 2010

TOTAL BUDGETED AMOUNTS			
\$679,004.15	\$194,984.86	\$0.00	\$873,989.01

DATE RECEIVED	GROSS ASSESSMENTS RECEIVED	COMMISSIONS	PENALTIES / DISCOUNTS	INTEREST	NET AMOUNT RECEIVED	GENERAL	1999 DEBT SERVICE	DEBT SERVICE	TOTAL
						77.69%	22.31%	0.00%	100.00%
11/18/09	\$57,593.68	\$827.43	\$2,431.51	\$0.00	\$54,334.74	\$42,212.66	\$12,122.08	\$0.00	\$54,334.74
11/30/09	\$178,802.48	\$2,574.76	\$7,152.04	\$0.00	\$169,075.68	\$131,354.90	\$37,720.78	\$0.00	\$169,075.68
12/14/09	\$333,141.63	\$4,797.35	\$13,318.41	\$0.00	\$315,025.87	\$244,743.60	\$70,282.27	\$0.00	\$315,025.87
12/30/09	\$55,339.14	\$797.14	\$2,196.22	\$0.00	\$52,345.78	\$40,667.44	\$11,678.34	\$0.00	\$52,345.78
01/29/10	\$25,131.23	\$365.49	\$765.45	\$139.63	\$24,139.92	\$18,754.30	\$5,385.62	\$0.00	\$24,139.92
02/12/10	\$15,656.57	\$229.45	\$360.03	\$0.00	\$15,067.09	\$11,705.82	\$3,361.47	\$0.00	\$15,067.09
03/31/10	\$43,320.02	\$649.80	\$0.00	\$0.00	\$42,670.22	\$33,150.49	\$9,519.73	\$0.00	\$42,670.22
04/23/10	\$103,981.32	\$1,559.72	\$0.00	\$28.01	\$102,449.61	\$79,593.10	\$22,856.51	\$0.00	\$102,449.61
05/21/10	\$8,986.75	\$134.80	\$0.00	\$0.00	\$8,851.95	\$6,877.08	\$1,974.87	\$0.00	\$8,851.95
06/04/10	\$48,410.04	\$758.19	(\$2,136.15)	\$0.00	\$49,788.00	\$38,680.30	\$11,107.70	\$0.00	\$49,788.00
08/25/10	\$4,211.56	\$0.00	\$0.00	\$0.00	\$4,211.56	\$3,271.96	\$939.60	\$0.00	\$4,211.56
10/12/09	\$0.00	\$0.00	\$0.00	\$0.00	\$0.00	\$0.00	\$0.00	\$0.00	\$0.00
10/13/09	\$0.00	\$0.00	\$0.00	\$0.00	\$0.00	\$0.00	\$0.00	\$0.00	\$0.00
10/14/09	\$0.00	\$0.00	\$0.00	\$0.00	\$0.00	\$0.00	\$0.00	\$0.00	\$0.00
10/15/09	\$0.00	\$0.00	\$0.00	\$0.00	\$0.00	\$0.00	\$0.00	\$0.00	\$0.00
10/16/09	\$0.00	\$0.00	\$0.00	\$0.00	\$0.00	\$0.00	\$0.00	\$0.00	\$0.00
TOTALS	\$874,574.42	\$12,694.13	\$24,087.51	\$167.64	\$837,960.42	\$651,011.45	\$186,948.97	\$0.00	\$837,960.42

GF	\$9,862.07	\$130.24
DS	\$2,832.06	\$37.40

Description	General	Debt Service - 201	Debt Service	Total
Gross Levy	\$679,004.15	\$194,984.86	\$0.00	\$873,989.01
Discounts	\$0.00	\$0.00	\$0.00	\$0.00
Property Appraisal	\$0.00	\$0.00	\$0.00	\$0.00
Tax Collector	\$0.00	\$0.00	\$0.00	\$0.00
Net Collections:	\$679,004.15	\$194,984.86	\$0.00	\$873,989.01
Dist Percent	77.69%	22.31%	0.00%	100.00%
General Fund	\$660,743.28	\$189,743.63		
Debt Service				

D/S Transfers	Date	Amount
140,550.56	03/22/10	
9,519.73	04/05/10	
23,198.23	05/15/10	
1,633.15	05/26/10	
11,107.70	06/25/10	
	08/31/10	

Total Transferred \$186,009.37
Total Remaining \$939.60

Collection Percentage 100.07%

BOND DEBT SERVICE

Lakeside Plantation Community Development District
Capital Improvement Revenue Bonds, Series 1999A

Period Ending	Principal	Coupon	Interest	Debt Service	Annual Debt Service
11/01/2008			72,453.75	72,453.75	72,453.75
05/01/2009	40,000	6.950%	72,453.75	112,453.75	
11/01/2009			71,063.75	71,063.75	183,517.50
05/01/2010	40,000	6.950%	71,063.75	111,063.75	
11/01/2010			69,673.75	69,673.75	180,737.50
05/01/2011	45,000	6.950%	69,673.75	114,673.75	
11/01/2011			68,110.00	68,110.00	182,783.75
05/01/2012	45,000	6.950%	68,110.00	113,110.00	
11/01/2012			66,546.25	66,546.25	179,656.25
05/01/2013	50,000	6.950%	66,546.25	116,546.25	
11/01/2013			64,808.75	64,808.75	181,355.00
05/01/2014	55,000	6.950%	64,808.75	119,808.75	
11/01/2014			62,897.50	62,897.50	182,706.25
05/01/2015	60,000	6.950%	62,897.50	122,897.50	
11/01/2015			60,812.50	60,812.50	183,710.00
05/01/2016	60,000	6.950%	60,812.50	120,812.50	
11/01/2016			58,727.50	58,727.50	179,540.00
05/01/2017	65,000	6.950%	58,727.50	123,727.50	
11/01/2017			56,468.75	56,468.75	180,196.25
05/01/2018	70,000	6.950%	56,468.75	126,468.75	
11/01/2018			54,036.25	54,036.25	180,505.00
05/01/2019	75,000	6.950%	54,036.25	129,036.25	
11/01/2019			51,430.00	51,430.00	180,466.25
05/01/2020	80,000	6.950%	51,430.00	131,430.00	
11/01/2020			48,650.00	48,650.00	180,080.00
05/01/2021	85,000	6.950%	48,650.00	133,650.00	
11/01/2021			45,696.25	45,696.25	179,346.25
05/01/2022	95,000	6.950%	45,696.25	140,696.25	
11/01/2022			42,395.00	42,395.00	183,091.25
05/01/2023	100,000	6.950%	42,395.00	142,395.00	
11/01/2023			38,920.00	38,920.00	181,315.00
05/01/2024	110,000	6.950%	38,920.00	148,920.00	
11/01/2024			35,097.50	35,097.50	184,017.50
05/01/2025	115,000	6.950%	35,097.50	150,097.50	
11/01/2025			31,101.25	31,101.25	181,198.75
05/01/2026	125,000	6.950%	31,101.25	156,101.25	
11/01/2026			26,757.50	26,757.50	182,858.75
05/01/2027	135,000	6.950%	26,757.50	161,757.50	
11/01/2027			22,066.25	22,066.25	183,823.75
05/01/2028	140,000	6.950%	22,066.25	162,066.25	
11/01/2028			17,201.25	17,201.25	179,267.50
05/01/2029	155,000	6.950%	17,201.25	172,201.25	
11/01/2029			11,815.00	11,815.00	184,016.25
05/01/2030	165,000	6.950%	11,815.00	176,815.00	
11/01/2030			6,081.25	6,081.25	182,896.25
05/01/2031	175,000	6.950%	6,081.25	181,081.25	
11/01/2031					181,081.25
	2,085,000		2,165,620.00	4,250,620.00	4,250,620.00

Lakeside Plantation CDD
Profit & Loss by Job
 August 2010

Ordinary Income/Expense	Activates	End of Summer	Ice Cream Social	Pizza	Wine & Cheese	TOTAL
Attendance:						
Income		225	34	16	32	
Other Income	0.00	0.00	0.00	0.00	0.00	0.00
Total Income	0.00	0.00	0.00	0.00	0.00	0.00
Gross Profit	0.00	0.00	0.00	0.00	0.00	0.00
Expense						
Expenses						
Entertainment	0.00	500.00	0.00	0.00	0.00	
Food	0.00	436.37	32.14	63.14	101.63	633.28
Misc. Supplies	46.55	88.39	0.00	0.00	0.00	134.94
Rental-Events	0.00	275.60	0.00	0.00	0.00	
Total Expenses	46.55	1,300.36	32.14	63.14	101.63	768.22
Total Expense	46.55	1,300.36	32.14	63.14	101.63	1,543.82
Net Ordinary Income	-46.55	-1,300.36	-32.14	-63.14	-101.63	-1,543.82
Net Income	-46.55	-1,300.36	-32.14	-63.14	-101.63	-1,543.82

Lakeside Plantation Community Development District

Check/Voucher Register - Check Register Diane

10102 - Cash-BB&T Activities A/C

From 8/1/2010 Through 8/31/2010

Ch...	Check D...	Vendor Name	Invoice Number	Transaction Description	Check Amount
2078	8/16/2010	Bella Napoli		Pizza	63.14
2080	8/28/2010	Samuel Jolly		End of Summer Party	500.00
2081	8/28/2010	Michael's		End of Summer Supplies	16.94
2082	8/28/2010	Do All Rental		End of Summer Rentals	275.60
Report Total					855.68

Lakeside Plantation Community Development District

Check/Voucher Register - Check Register Diane

10101 - Cash-BB&T Operating A/C

From 8/1/2010 Through 8/31/2010

Ch...	Check D...	Vendor Name	Invoice Number	Transaction Description	Check Amount
1927	8/1/2010	Clinton Casual	6947	2 Umbrellas	80.00
1928	8/1/2010	Constant Contact	YZ5LWIDAB20710	6 Months Services Event Marketing E-Mails	216.00
1929	8/1/2010	District Management S...	2264	July Management Service w/ Semi Mo Staffing Program	9,816.67
1930	8/1/2010	Florida Power & Light C...	04126-05586 -081610	Electric Service 06/24-07/26/10	201.77
1931	8/1/2010	Florida Power & Light C...	57421-67439-0816	Electric Service 06/24-07/26/10	947.68
1932	8/1/2010	Florida Power & Light C...	84595-15071 081610	Electric Service 06/24/10-07/26/10	1,234.34
1933	8/1/2010	Florida Department of ...	9980275-14397432-063010	Unemployment Claims - April,May & June 2010-C.Greus	3,300.00
1934	8/1/2010	Laura West	LW-Reim Exp	Reim for Postage-Package w/ Invoice sent to DMS	4.19
1935	8/1/2010	Teal Lawn	10913	Cut Back & remove 2 Bougain. from Entry Trellis	840.00
1936	8/1/2010	TECO Peoples Gas	10332096 - 0811110	Gas Services 6/19-7/10	12.77
1937	8/1/2010	Venice Gondolier Sun	240770	Notice of Public Hearing-08/12/10 2011 Budget	183.60
1938	8/1/2010	Venice - Medical Depar...	150440	Scale Seca Column Model 700	349.00
1939	8/1/2010	Wal-Mart Community	6032 2020 1028 8471-0705	Misc.Supplies-Food,Helium,Games&Supplies	132.48
1940	8/15/2010	Culligan Water Conditio...	1017805-0731	Drinking Water & Cups w/ service charge	161.50
1941	8/15/2010	District Management S...	2265	Semi Mo. Billing for Staffing Programs	6,025.00
1942	8/15/2010	Lake Masters Aquatic ...	10-45514	Monthly Service-Treatment of Water & Canals August	866.00
1943	8/15/2010	Lakeside Plantation CDD	LSP0804	Series 200-DS #6753360- Tax Revenue Interest	2.37
1944	8/15/2010	North Port Solid Waste ...	54883-159826-0802	3 Auto Containers 06/30/10-07/31/10	96.00
1945	8/15/2010	North Port Utilities	43123-154656-072810	Water Service 06/18-07/21/10	561.08
1946	8/15/2010	North Port Utilities	43123-154658-072810	Water Services 06/18/10-07/21/10	20.82
1947	8/15/2010	North Port Utilities	43123-156052-072810	Water Service 06/18/10-07/21/10	125.18
1948	8/15/2010	Security Alarm Corp.	86155	Monitoring Commerical Fire Basic 08/01/10-10/31/10	147.00
1949	8/15/2010	Sparkle Brite Pool of N...	80451	Chlorine AAA De Filter Powder	37.66
		Sparkle Brite Pool of N...	80452	AAA Sodium Bicarb	27.31
		Sparkle Brite Pool of N...	80967	Chlorine	24.15
		Sparkle Brite Pool of N...	81270	Chlorine.AAA De Filter Powder	36.70
		Sparkle Brite Pool of N...	81815	Hay Flush Plug, Chlorine	30.99
		Sparkle Brite Pool of N...	82170	Chlorine	27.74
		Sparkle Brite Pool of N...	82423	New Sticks 8oz,AAA De Filter Powder	182.74
		Sparkle Brite Pool of N...	82567	Chlorine	14.08
1950	8/15/2010	Staples Credit Plan	6035 5178 7242 8692-081610	Yellow,Magenta,Cyan& Black Ink & Copy Paper	145.44
1951	8/15/2010	Teal Lawn	10837	August Landscape Maint.	6,100.00
1952	8/17/2010	Anthony A. Parkerson	100	Removed a Browser hijacker from Computer System	67.50
1953	8/17/2010	Bob Babik	BB-081210	Supervisor Fee Meeting 08/12/10	200.00
1954	8/17/2010	Gwynne Balson	GB-081210	Supervisor Fee Meeting 08/12/10	200.00
1955	8/17/2010	Ronald Bock	RB-081210	Supervisor Fee Meeting 08/12/10	200.00
1956	8/17/2010	William Capozzi	BC-081210	Supervisor Fee Meeting 08/12/10	200.00

Lakeside Plantation Community Development District

Check/Voucher Register - Check Register Diane

10101 - Cash-BB&T Operating A/C

From 8/1/2010 Through 8/31/2010

Ch...	Check D...	Vendor Name	Invoice Number	Transaction Description	Check Amount
1957	8/17/2010	Home Depot Credit Ser...	6035 3225 0282 9538-0825	C/house Supplies&Maint.s Bolt,papertowels,trash bags,boxes	200.78
1958	8/17/2010	Office Outfitters, Inc.	080410	U shaped Receptions Deck & Brigde + Deliv. Chрге	785.00
1959	8/17/2010	Ron Adams A/C, Inc.	2908	Install New A/C Disconnect	144.70
1960	8/18/2010	David Polk	DP 081210	Supervisor Fee Meeting 8/12/10	200.00
1961	8/30/2010	Comcast Communicatio...	15515 999177-02-9 0814	Phone & Internet Service 08/24-09/23	396.87
1962	8/30/2010	Lisa Cantillo	082610	Design Consultation for Multi Purpose Room	300.00
1963	8/30/2010	Shumaker, Loop & Ken...	229929	Legal Service General Matters May 2010	525.00
	8/30/2010	Shumaker, Loop & Ken...	237549	General June 15,2010	17.50
1964	8/30/2010	TECO Peoples Gas	10332096-090910	Gas 07/11/10-08/17/10	12.77
1965	8/30/2010	Teixeira Construction, I...	C/house First Draw	Clubhouse Draw #1	18,417.00
	8/30/2010	Teixeira Construction, I...	Entry First Draw	Entry / Arbors Draw#1	23,283.00
Report Total					77,100.38

1939
8/1/2010

Amount \$132.48
WALMART

NC (813) 496-5796 J.1077MBJ 3/19/255

0003 0004

LAKESSIDE PLANTATION
CDD
AUTHORIZED BUYER # 01003

ACCOUNT #
INVOICE# 007858
TRANSACTION # 7888

DATE OF SALE #: 061810
AUTHORIZATION # 010134

P.O. #:
STORE #: 00003387
REGISTER #: 12

S.K.U	DESCRIPTION	QUANTITY	UNIT	PRICE	EXT. PRICE
063554593	1CT RND TC WHITE	4.000	EA	1.5000	6.00
063554595	1CT RND TC RAV RED	4.000	EA	1.5000	6.00
063554599	1CT RND TC ELECTBLUE	4.000	EA	1.5000	6.00
063554623	1CT RND TC SF YELLOW	4.000	EA	1.5000	6.00

TAX \$1.88
SUB \$24.00

TOTAL INVOICE \$26.88
CREDITS TOTAL \$0.00
BALANCE DUE \$26.88

LAKESSIDE PLANTATION
CDD
AUTHORIZED BUYER # 02000

ACCOUNT #
INVOICE# 000137
TRANSACTION # 137

DATE OF SALE #: 061810
AUTHORIZATION # 010408

P.O. #:
STORE #: 00003387
REGISTER #: 5

S.K.U	DESCRIPTION	QUANTITY	UNIT	PRICE	EXT. PRICE
036397997	GV LT BR SUGAR 2 LB	1.000	EA	1.3600	1.36
051206640	GV NSA APPLE PIE FIL	5.000	EA	1.6800	8.40
056889130	BADIA VAN EXT	1.000	EA	2.5800	2.58
071656389	GV VIT O MILK	1.000	EA	2.1300	2.13

TAX \$0.00
SUB \$14.47

TOTAL INVOICE \$14.47
CREDITS TOTAL \$0.00
BALANCE DUE \$14.47

LAKESSIDE PLANTATION
CDD
AUTHORIZED BUYER # 02000

ACCOUNT #
INVOICE# 004135
TRANSACTION # 4135

DATE OF SALE #: 062610
AUTHORIZATION # 025711

P.O. #:
STORE #: 00003387
REGISTER #: 5

S.K.U	DESCRIPTION	QUANTITY	UNIT	PRICE	EXT. PRICE
011795312	SMKR MAGIC SHELL	1.000	EA	1.6800	1.68
050026303	DOVE MILK 9.5 OZ	2.000	EA	3.0000	6.00

TAX \$0.00
SUB \$7.68

TOTAL INVOICE \$7.68
CREDITS TOTAL \$0.00
BALANCE DUE \$7.68

LAKESSIDE PLANTATION
CDD
AUTHORIZED BUYER # 02000

ACCOUNT #
INVOICE# 009004
TRANSACTION # 9004

DATE OF SALE #: 070510
AUTHORIZATION # 008454

P.O. #:
STORE #: 00003387
REGISTER #: 15

S.K.U	DESCRIPTION	QUANTITY	UNIT	PRICE	EXT. PRICE
039055431	BALLOONTIME HELIUM	1.000	EA	19.7500	19.75
053408119	DUB BUB S FLVR	1.000	EA	1.5600	1.56
056598623	ROY HD AA44	1.000	EA	0.9700	0.97
056884370	MAUI WAVE HOOP	4.000	EA	5.0000	20.00
059206387	UNO CARDS	1.000	EA	4.4400	4.44
059432599	#10 MARBLE PLAYBALL	1.000	EA	1.0000	1.00
063073072	12IN PUMP	1.000	EA	4.8600	4.86
066945737	GAME OF LIFE	1.000	EA	15.8400	15.84
06896717	OPERATION	1.000	EA	14.9600	14.95
070483966	9" ASST NEON BALLOON	1.000	EA	1.2500	1.25

TAX \$0.00
SUB \$84.66

TOTAL INVOICE \$84.65
CREDITS TOTAL \$0.00
BALANCE DUE \$84.65

Commit Payment To:
 HOME DEPOT CREDIT SERVICES
 PO BOX 9055
 DES MOINES, IA 50368-9055

ACCOUNT: 1
 LAKESIDE PLANTATION CDD
 2002 N LOUIS AVE., STE. 507
 TAMPA FL 33607-2393

82533

Payment Due Date: 08/25/2010
 Please make checks payable to: HOME DEPOT CREDIT SERVICES



Acct #
LAKESIDE PLANTATION CDD

Purchased by: TERPSTRA RICHARD
Invoice: 4122170

Ship To:
Purchase Order/ Job Name:

Amount Due: 74.40

Customer Agreement #: Transaction Date: 07/05/2010

Store #, Location: 8528, NORTH PORT

SKU #	PRODUCT	QTY	UNIT PRICE	TOTAL PRICE
0000452716	GLAD106CTQT	1.0000	EA 9.99	9.99
0000173041	BOUNTY 8 BIG	1.0000	EA 11.97	11.97
0000600372	TANK EXCHNGE	1.0000	EA 17.82	17.82
0000740321	HUSKY 45 GAL	1.0000	CA 13.28	13.28
0000308242	WISE GRIP	1.0000	EA 12.94	12.94
0000233986	AIM-N-FLAME	1.0000	EA 2.97	2.97
-continued				

Acct #
LAKESIDE PLANTATION CDD

Purchased by: TERPSTRA RICHARD
Invoice: 4122170

Ship To:
Purchase Order/ Job Name:

Amount Due: 74.40

Customer Agreement #: Transaction Date: 07/05/2010

Store #, Location: 8528, NORTH PORT

SKU #	PRODUCT	QTY	UNIT PRICE	TOTAL PRICE
0000233986	AIM-N-FLAME	1.0000	EA 2.97	2.97
0000646539	12X1/2"TAPE	1.0000	EA 2.46	2.46
SUBTOTAL				74.40
TAX				0.00
SHIPPING				0.00
TOTAL				74.40

Acct #:
LAKESIDE PLANTATION CDD

Purchased by: TERPSTRA RICHARD
Invoice: 3050152

Ship To:
Purchase Order/ Job Name:

Amount Due: 17.31

Customer Agreement #: Transaction Date: 07/16/2010

Store #, Location: 8528, NORTH PORT

SKU #	PRODUCT	QTY	UNIT PRICE	TOTAL PRICE
0000436971	1/4HEXNUTSS	8.0000	EA 0.25	2.00
0000204054	HEX BOLT	8.0000	EA 0.45	3.60
0000497124	EC 2.6OZ	1.0000	EA 2.79	2.79
0000203110	40CAML4PK	1.0000	EA 3.97	3.97
0000254827	PLASTBAGGDS	1.0000	EA 0.98	0.98
0000133750	25DL BNT 4	1.0000	EA 3.97	3.97
SUBTOTAL				17.31
TAX				0.00
SHIPPING				0.00
TOTAL				17.31

Acct #:
LAKESIDE PLANTATION CDD

Purchased by: TERPSTRA RICHARD
Invoice: 9044549

Ship To:
Purchase Order/ Job Name:

Amount Due: 18.43

Customer Agreement #: Transaction Date: 07/20/2010

Store #, Location: 8528, NORTH PORT

SKU #	PRODUCT	QTY	UNIT PRICE	TOTAL PRICE
0000369894	SMALL BOXES	10.0000	EA 0.67	6.70
0000199957	TAPE	1.0000	EA 5.97	5.97
0000424737	FIX A FLAT	1.0000	EA 5.76	5.76
SUBTOTAL				18.43
TAX				0.00
SHIPPING				0.00
TOTAL				18.43

Remit Payment To:
 HOME DEPOT CREDIT SERVICES
 PO BOX 9055
 DES MOINES, IA 50368-9055

ACCOUNT:
 LAKESIDE PLANTATION CDD
 2002 N LOUIS AVE., STE. 507
 TAMPA FL 33607-2393

82534

Payment Due Date: 08/25/2010
 Please make checks payable to: HOME DEPOT CREDIT SERVICES



Acct # LAKESIDE PLANTATION CDD					Acct # LAKESIDE PLANTATION CDD				
Purchased by: TERPSTRA RICHARD		Invoice: 9992128			Purchased by: CAPOZZI WILLIAM		Invoice: 6052407		
Ship To:		Purchase Order/ Job Name:			Ship To:		Purchase Order/ Job Name:		
Amount Due: 52.65					Amount Due: 37.99				
Customer Agreement #:		Transaction Date: 07/20/2010			Customer Agreement #:		Transaction Date: 08/02/2010		
Store #, Location: 0273, VENICE					Store #, Location: 8528, NORTH PORT				
<u>SKU #</u>	<u>PRODUCT</u>	<u>QTY</u>	<u>UNIT PRICE</u>	<u>TOTAL PRICE</u>	<u>SKU #</u>	<u>PRODUCT</u>	<u>QTY</u>	<u>UNIT PRICE</u>	<u>TOTAL PRICE</u>
0000369894	SMALL BOXES	1.0000 EA	0.67	0.67	0000123460	3STEPSTOOL	1.0000 EA	37.99	37.99
0000369894	SMALL BOXES	1.0000 EA	0.67	0.67					
0000369894	SMALL BOXES	1.0000 EA	0.67	0.67					
0000464768	HND TRK. 600	1.0000 EA	49.97	49.97					
0000369894	SMALL BOXES	1.0000 EA	0.67	0.67					
				SUBTOTAL TAX SHIPPING TOTAL				SUBTOTAL TAX SHIPPING TOTAL	
				52.65				37.99	37.99

LAKESIDE PLANTATION COMMUNITY DEVELOPMENT DISTRICT

District Office ♦ 2002 North Lois Avenue ♦ Suite 507 ♦ Tampa, Florida 33607 ♦ (813) 873-7300 ♦ Fax (813) 873-7070

To: Board of Supervisors
From: Brian K. Lamb
Date: September 15, 2010
Re: Amenities Report

The Amenities team has conducted two event planning meetings and received a number of great ideas from residents. In October the Amenities team will take a bus trip to Tampa to visit the Art Museum.

Great events have been planned and we anticipate overwhelming success. The End of Summer party in August was attended by approximately 235 individuals. The children enjoyed various activities with some of the following highlights:

- “Stoney” the mascot for the Port Charlotte Stone Crabs Baseball Team visited with the children.
- The Bounce House, was a great hit with the children.

We are continuing developing and scheduling outside competition for the Bocca Ball Club. Another fun activity was the free salsa class, which turned out to be spicy hot and a lot of fun. To cool down from the spicy hot night of the free salsa class, we had an Ice Cream social where we made banana splits.

The month of October is filled with more exciting activities. We are adding to our calendar a “Healthier You Program.” Once per month we will discuss diet, exercise, and practicing a healthy lifestyle.

Let us not forget that October we will be celebrating Halloween with many activities going on. There will be a Halloween party on October 29th and many awards will be given out:

- Home Decorating Contest
- Children Costume Contest
- Scare Crow Contest

We are so excited that our calendar is filling up with a lot of fun activities for our families. However, activities will have to be cancelled if we don't have the volunteers to run them. So please do your part so we can all enjoy.

**LAKESIDE PLANTATION
COMMUNITY DEVELOPMENT DISTRICT**

District Office ♦ 2002 North Lois Avenue ♦ Suite 507 ♦ Tampa, Florida 33607 ♦ (813) 873-7300 ♦ Fax (813) 873-7070

To: Board of Supervisors
From: Brian K. Lamb
Date: September 15, 2010
Re: Clubhouse Report

Supervisor Babik has met with several vendors and interested parties in the community and has found the researched the following items for consideration. A general diagram is attached as hand drawn for purposes of illustration and discussion.

Childrens Playground (8-15yrs)	\$26,000
Volleyball Court	\$5,000
Shuffle Board Courts	\$8,000
Golf Putting Range	\$11,500
Connecting Sidewalks	\$6,500

